

## Hydraulic Pan & Tilt PT 3636-C

### Features

- Improved reliability
- Built in flow restrictors
- Uniform sweep speeds in all forward and reverse directions
- Pre-configurable pan and tilt envelopes between 0 and 360°
- Cast aluminium body
- Mounting flexibility offered by two mounting brackets

Following the overwhelming success of the PT3636 Hydraulic Pan & Tilt Unit, Tritech have continued to improve the design characteristics offered and have released a new improved pan and tilt unit.

The Tritech PT3636-C hydraulic pan and tilt unit has been designed to eliminate a number of potential weak points that were identified on other hydraulic pan and tilt units. Designed to be rugged, compact and reliable the PT3636-C is the ideal solution for use on subsea vehicles, where the harsh working environment tests equipment reliability to the limit.

All hydraulic connections for the PT3636-C are located in the mounting base, which allows the unit to be installed using rigid rather than flexible piping. By using rigid piping the system offers reduced interference and smooth operation of cameras and lights, which in turn increases the efficiency and reliability of the unit.



The integral mounting bracket has been designed with practical slots for band clamps. This provides a simple method for mounting numerous combinations of different sized cameras and lights.

This stylishly designed compact hydraulic pan and tilt unit has been designed to work efficiently and reliably when mounted in a restricted area.

## Specifications

COPYRIGHT SUB-ATLANTIC 2001

PAN & TILT MOVEMENTS ARE 360° MAXIMUM. MAXIMUM ANGLE CAN BE REDUCED BY REMOVING CYLINDERS AND FITTING 15° SPACERS INSIDE TO OBTAIN DESIRED ANGLE OF ROTATION.

WEIGHT IN AIR: 3 kg  
 WEIGHT IN SEAWATER: 2 kg  
 SPECIFIC TORQUE: 0.28 Nm/BAR  
 MAX. PRESSURE: 200 BAR

CAN BE MOUNTED AS SHOWN OR INVERTED

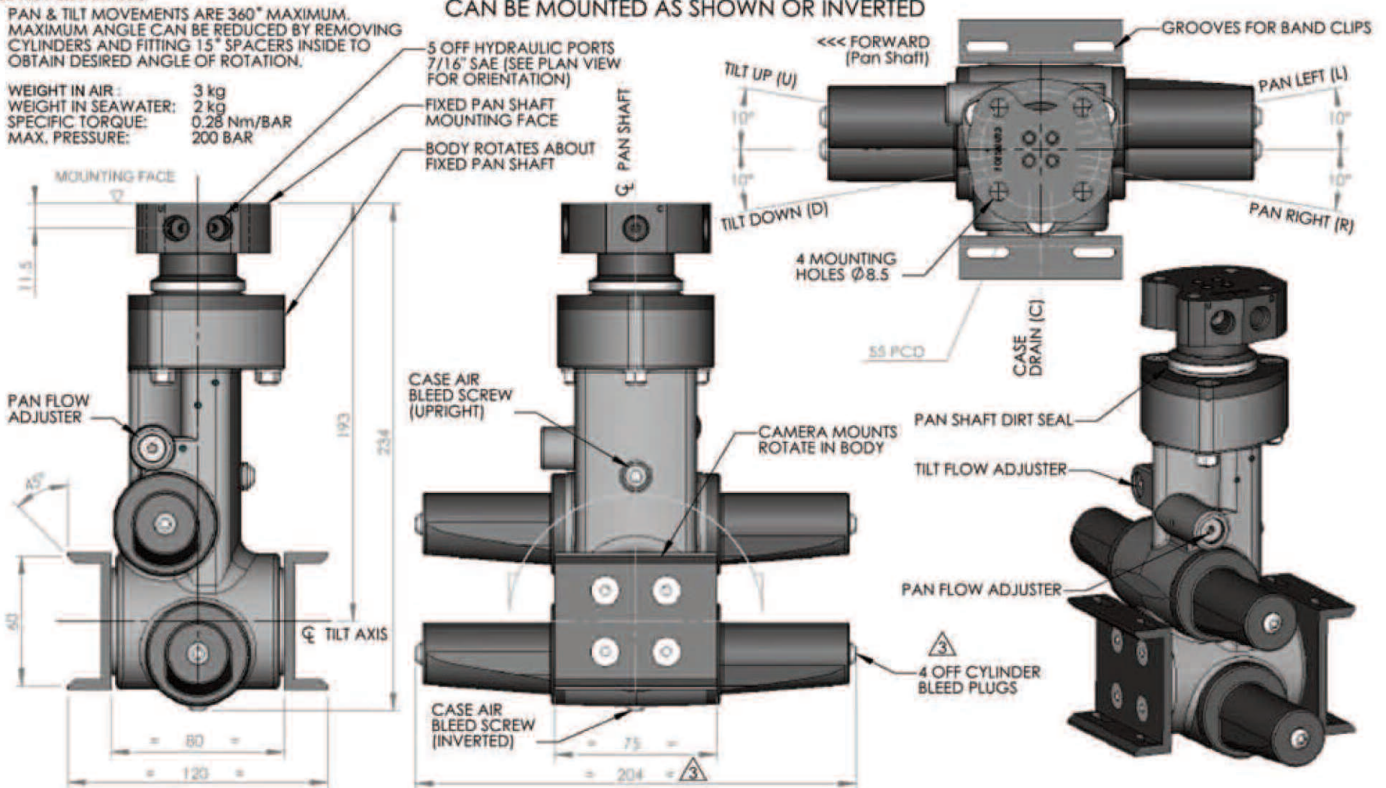

<b>Pan Angle</b>	360° Adjustable
<b>Tilt Angle</b>	360° Adjustable
<b>Torque</b>	56 Nm @200Bar
<b>Specific Torque</b>	0.28 Nm / Bar
<b>Recommended max. payload</b>	8 kg total
<b>Single side limit</b>	5 kg
<b>Nominal Working Pressure</b>	100 Bar
<b>Maximum Pressure</b>	200 Bar
<b>Overall Height</b>	234 mm
<b>Overall Length</b>	204 mm
<b>Overall Width</b>	120 mm
<b>Weight in Air</b>	3 kg
<b>Weight in Water</b>	2 kg
<b>Hydraulic ports</b>	7/16" SAE
<b>Materials</b>	Cast Anodised Aluminium Alloy and Stainless Steel

All specifications are subject to change in line with Tritech's policy of continual product development.

Designed and built by Sub-Atlantic Limited, U.K.  
 Ref: EDS-HYD-004.5