

ZipTrench ROV Trenching Tool

Features

- High Flow Rate
- Low Operating Pressures
- Negligible Upthrust in Operation
- Compact and Rugged
- Low Maintenance Costs
- Lightweight Plastic Construction

Applications

- Seabed Trenching
- Deburial
- Cable Trenching and Maintenance
- Smaller Pipe and Flowline Trenching and Deburial
- Marine Archaeology



The Tritech ROV mounted ZipTrench trenching and excavation tool has been developed from the highly successful ZipJet and ZipJet Ultra family of products, to meet the requirement for cost-effective, simple to deploy and use trenching equipment.

The unique design and positioning of the inlet and outlet ports eliminates upthrust while the pump is in operation. Thus less vehicle power is used in compensating for the thrust, the vehicle is more stable in operation, and more of the power can go to operating the ZipTrench.

The body of the trencher is manufactured from substantial plastic materials designed to resist erosion and general day to day offshore work. The simple design results in excellent reliability.

The trencher is designed to open up trenches and for deburial in unconsolidated sediments. The types of materials will typically include sand, fine gravels and muds - the materials normally encountered where an existing trench has naturally backfilled.

The principle of operation is to disperse the sediments in a large mass flow of water. This has benefits over conventional dredging pumps when all that is required is to open a trench or effect deburial without needing to be concerned where the material comes to rest.

Where uniform seabed conditions occur with no obstructions, boulders or rocks, the trenching rate can be improved using flow guide templates.

Specifications

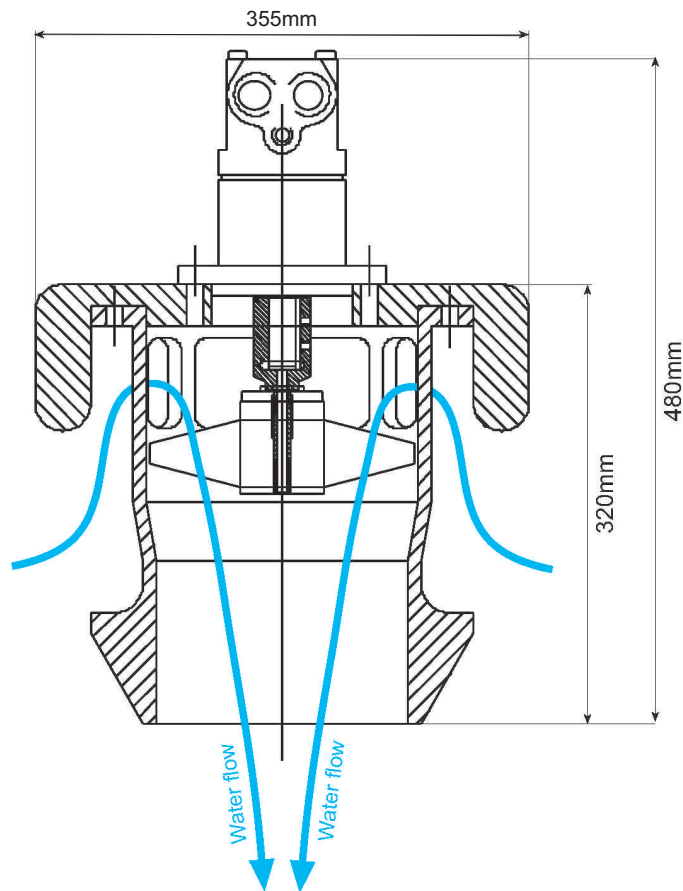

Hydraulics

Pressure	2200 - 4000 psi (152 - 276 bar)
Flow	10 - 15 gpm (45 - 70 litres/min)
Supply and return connections	No 12 JIC male
Case drain connection	No 6 JIC male

Trenching Performance

Deburial rate	up to 50 cubic metres/hour
Nominal water throughput	1000 cubic metres/hour

General

Motor Type	Volvo F11 - 10
Overall length	480mm
Overall diameter	355mm
Weight in Air	21 kg
Weight in Water	12.5 kg
Materials	Oilon Nylon, Nylatron GSM, Aluminium, Stainless Steel
Effective reactive thrust	None

All specifications are subject to change in line with Tritech's policy of continual product development.

Ref: EDS-HYD-005.3