

Gemini 720is

Real-time, forward-looking multibeam imaging sonar

The Gemini 720is is a key product in Tritech's renowned multibeam sonar range and offers a realtime, high frequency imaging solution. The Gemini 720is operates at 720 kHz and this combined with Tritech's state-of-the-art processing electronics, produces images of superb clarity in harsh and deep water applications.

The industry standard Gemini 720is sonar features, a wide 120deg horizontal field of view and has improved attenuation of waterborne electrical noise for optimal imaging performance. An integrated velocity-of-sound sensor ensures that a target is displayed to a high degree of positional accuracy. CHIRP processing provides improved target separation over longer ranges.

The 720is is fully compatible with Tritech's software package, Genesis. This ensures improved user interaction and allows for control of multiple Tritech products from within one software package. Software development kits (SDK) are also available for Windows and Linux operation systems.



Benefits

- Near field focusing
- 4 mm / 0.2 in range
- Clear wide angle field of view
- Suitable for low visibility environments
- Easier interpretation of sonar

Features

- 720 kHz operating frequency
- CHIRP processing
- Wide 120° field of view
- Real-time updates for video like imagery
- Integrated velocimeter for accurate ranging

Key Specification	Low Frequency Mode
Operating frequency	720 kHz
Angular resolution	1.0° acoustic, 0.25° effective
Range	0.1 m - 120 m / 4 in - 394 ft
Depth rating	1000 m / 3281 ft (Aluminium) 4000 m / 13123 ft (Titanium)
Supply Voltage	19 to 74 VDC
Power Requirements	16 - 27 W (range dependent)
Main Port Protocol	Ethernet or VDSL
Weight in air	3.40 kg / 7.50 lbs (Aluminium) or 5.00 kg / 11.02 lbs (Titanium)
Weight in water	1.30 kg / 2.86 lbs (Aluminium) or 3.00 kg / 6.61 lbs (Titanium)

Acoustic specifications	Low frequency mode
Operating frequency	720 kHz
Angular resolution	1.0° acoustic, 0.25° effective
Range	0.1 m - 120 m / 4 in - 394 ft
Number of beams	512
Horizontal beam width	120°
Vertical beam width	20° (tilted down 10°)
Range resolution	4 mm & 8 mm / 0.2 in & 0.3 in
Update rate	5 - 97 Hz (range dependent)
Mode of operation	CHIRP and CW
Speed of sound	Integrated Velocity of Sound sensor for accuracy

Interface

Supply voltage	19 to 74 VDC
Power requirement	16 - 27 W (range dependent) ¹
Main port protocol	Ethernet or VDSL
Auxiliary port protocol	RS232, RS485 (half duplex), TTL in, Ethernet
Auxiliary port output power	24 V regulated output with a maximum capacity of up to 29 W to power other subsea equipment
Connector type	Seacon 55 series, Subconn FCR 15, BH10M series, Scorpion 420-K-FCRL or Schilling SeaNet

Physical specification

Depth rating	1000 m / 3281 ft (Aluminium) or 4000 m / 13123 ft (Titanium)
Weight in air	3.40 kg / 7.50 lbs (Aluminium) or 5.00 kg / 11.02 lbs (Titanium)
Weight in water	1.30 kg / 2.86 lbs (Aluminium) or 3.00 kg / 6.61 lbs (Titanium)
Temperature rating (operating)	-10 °C to 35 °C / 14 °F to 95 °F
Temperature rating (storage)	-20 °C to 50 °C / 4 °F to 122 °F
Dimensions	271 mm x 135 mm x 107 mm / 10.67 in x 5.32 in x 4.22 in

Software requirements	Minimum	Recommended
Included	Genesis	
Processor	2 GHz	3 GHz Quad Core
Graphics	3D hardware accelerated graphics card	
SDK	Available on request	
Operating system	Microsoft Windows 7, 10, 11	

Specification subject to change in line with Tritech's policy of continual product development

¹ The power consumption range quoted is accurate for a standalone unit and ignores cable losses

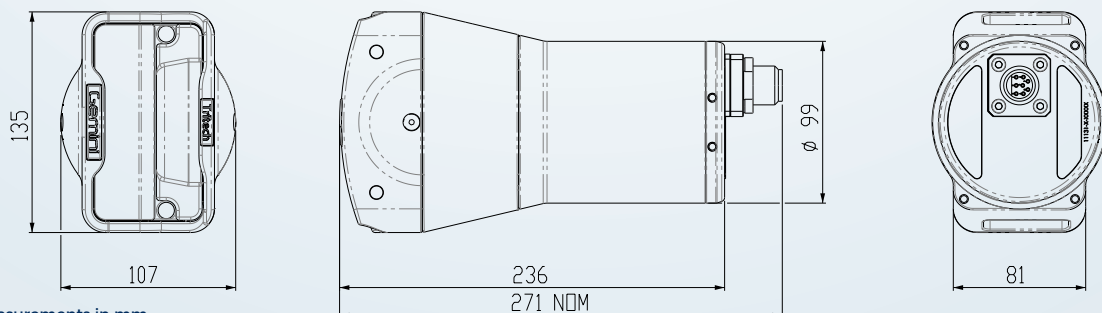

Not to scale. Measurements in mm