

Gemini 1200ikd

High resolution, dual-frequency forward-looking imaging multibeam sonar

Designed to operate in harsh and noisy environments the Gemini 1200ikd multibeam sonar operates at two acoustic frequencies, 720 kHz for long range target detection, and 1200 kHz for enhanced high-resolution imaging. The frequency can be set to automatically switch between 720 kHz and 1200 kHz at a specific range or changed manually. The sonar maintains a wide 120° horizontal field of view when operating at both acoustic frequencies.

The sonar actively attenuates waterborne electrical noise generated by other subsea equipment, including thrusters, to avoid the detrimental impact of such noise on the sonar image. An integrated speed-of-sound sensor ensures that targets are displayed to a high degree of positional accuracy. CHIRP processing provides improved target separation over longer ranges.

The 1200ikd is fully compatible with Trittech's software package, Genesis, which improves user interaction and allows for control of multiple Trittech products from within one software package.

To allow the 1200ikd to share bandwidth with other sensors on a shared network connection, the data bandwidth required by the sonar can be limited by capping the ping rate, reducing resolution, or enabling data compression.



Depth rated
500 m or 1000 m

Applications

- Obstacle avoidance
- ROV/AUV navigation
- Detailed object imaging
- Target detection
- Subsea monitoring

Features

- Short range detailed imaging
- Long range object detection
- 720 kHz or 1200 kHz operation
- Wide 120° horizontal field of view
- CHIRP processing
- Integrated speed-of-sound sensor for accurate ranging
- Real-time video-like imagery

Key Specification	Low Frequency Mode	High Frequency Mode
Operating frequency	720 kHz	1200 kHz
Angular resolution	1.0° acoustic, 0.25° effective	0.6° acoustic, 0.12° effective
Range	0.1 m - 120 m / 4 in - 394 ft	0.1 m - 50 m / 4 in - 164 ft
Depth rating	500 m or 1000 m / 1640 ft or 3280 ft	
Weight in water	0.44 kg / 0.97 lbs (500 m), 0.92 kg / 2.03 lbs (1000 m)	

Acoustic Specifications	Low Frequency Mode	High Frequency Mode
Operating frequency	720 kHz	1200 kHz
Angular resolution	1.0° acoustic, 0.25° effective	0.6° acoustic, 0.12° effective
Range	0.1 m - 120 m / 4 in - 394 ft	0.1 m - 50 m / 4 in - 164 ft
Number of beams	512	1024
Horizontal beam width	120°	120°
Vertical beam width	20°	12°
Range resolution	4 mm / 0.2 in	2.4 mm / 0.1 in
Update rate	5 - 40 Hz (range dependent)	
Mode of operation	CHIRP and CW	
Speed of sound	Integrated Speed-of-Sound sensor for accuracy	

Interface

Supply voltage	19 to 74 Vdc
Power requirement	9.5 W - 27 W (range dependent) ¹
Main port protocol	Ethernet
Auxiliary port protocol	RS232, TTL in, pass-through power (2.5 A max)
Connector type	Aegir Technologies Marine MKS (W) 07 (inter-mateable with Impulse equivalent)

Software Requirements

	Minimum	Recommended
Software application	Genesis	
Processor	2 GHz	3 GHz Quad Core
Graphics	3D hardware accelerated graphics card	
SDK	Available on request for Windows and Linux	
Operating system	Microsoft Windows 7, 10, 11	

Physical Specification

Depth rating	500 m or 1000 m / 1640 ft or 3280 ft
Weight in air	1.46 kg / 3.22 lbs (500 m), 2.03 kg / 4.47 lbs (1000 m)
Weight in water	0.44 kg / 0.97 lbs (500 m), 0.92 kg / 2.03 lbs (1000 m)
Temperature rating (operating)	-10 °C to 35 °C / 14 °F to 95 °F
Temperature rating (storage)	-20 °C to 50 °C / 4 °F to 122 °F

¹ The power consumption range quoted is accurate for a standalone unit and ignores cable losses

Specification subject to change in line with Tritech's policy of continual product development

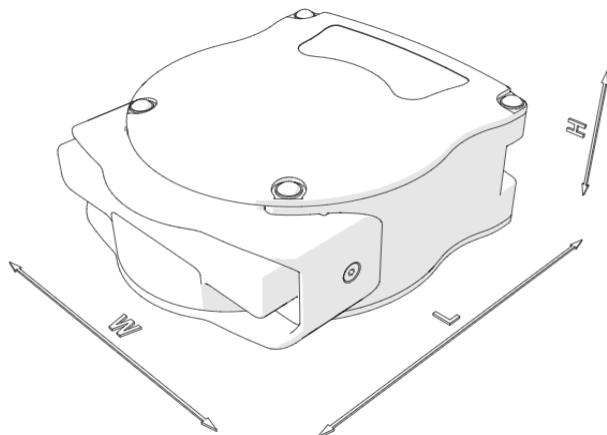

Model	Length (mm)	Width (mm)	Height (mm)
500 m	150	125	65
Inodive Mount (500m)	150	125	72
1000 m	150	125	77