

Micron Gemini

Product Manual

0729-SOM-00004 Rev 04



© Trittech International Ltd

The copyright in this document is the property of Trittech International Ltd. The document is supplied by Trittech International Ltd on the understanding that it may not be copied, used, or disclosed to others except as authorised in writing by Trittech International Ltd.

Trittech International Ltd reserves the right to change, modify and update designs and specifications as part of their ongoing product development programme. All product names are trademarks of their respective companies.

Open Source License Statement: This product includes software code developed by third parties, including software code subject to the GNU General Public License Version 2 ("GPLv2"). We will provide upon request the applicable GPL source code files via CD-ROM or similar storage medium for a nominal cost to cover shipping and media charges as allowed under the GPL. This offer is valid for a 3 year period from first manufacture of this product.

General Public License ("GPLv2") Inquiries: Please direct all GPL inquiries to the following address:

Trittech International Ltd
Peregrine Road
Westhill Business Park
Westhill, Aberdeenshire
AB32 6JL, UK

Table of Contents

Help & Support	4
Warning Symbols	5
Introduction	6
Technical Specifications	7
Sonar Variants.....	9
Getting started	10
Serial System Test Kit	11
Ethernet System Test Kit.....	12
Assembling the Serial System	13
Assembling the Ethernet System.....	15
Installation	16
Communications Protocols	16
Serial	16
Ethernet.....	17
Electrical Installation.....	18
Connector Maintenance Guidelines	18
Ground Fault Monitoring	18
Power	19
Hardware Installation.....	20
Micron Gemini AHRS Mounting	21
Installing the Micron Gemini using Trittech Mounts	22
Operation	29
Pressure Sensor (300m only).....	29
AHRS (Attitude Heading Reference System).....	30
AHRS Calibration.....	31
Maintenance	32
General guidance	32
After Use.....	32
Equipment Storage	32
Sacrificial Anode Information	33
Pressure Sensor Maintenance (300m only).....	34
Troubleshooting	35
Appendix A - Connector Details	38
Trittech Micron	38
Impulse Titan™	40
Souriau UTS6JC124S – S09126.....	42
USB to Serial Adapter Cable Options.....	42
Appendix B - Mounting Bracket Details	43
Appendix C - Setting the computer IP address in Windows® XP	45
Appendix D - Setting the computer IP address in Windows® 7 or Windows® 10	47

Help & Support

First please read this manual thoroughly (particularly the Troubleshooting section, if present). If a warranty is applicable, further details can be found in the Warranty Statement, 0080- STF-00139, available upon request.

Tritech International Ltd can be contacted as follows:



Mail

Tritech International Ltd
Peregrine Road
Westhill Business Park
Westhill, Aberdeenshire
AB32 6JL, UK



Telephone

+44 (0)1224 744111



Email

support@tritech.co.uk



Website

www.tritech.co.uk

Prior to contacting Tritech International Ltd please ensure that the following is available:

1. The Serial Numbers of the product and any Tritech International Ltd equipment connected directly or indirectly to it
2. Software or firmware revision numbers
3. A clear fault description
4. Details of any remedial action implemented

Contamination



If the product has been used in a contaminated or hazardous environment, you must de-contaminate the product and report any hazards prior to returning the unit for repair. Under no circumstances should a product be returned that is contaminated with radioactive material.

The name of the organisation which purchased the system is held on record at Tritech International Ltd and details of new software or hardware packages will be announced at regular intervals. This manual may not detail every aspect of operation and for the latest revision of the manual please refer to www.tritech.co.uk

Tritech International Ltd can only undertake to provide software support of systems loaded with the software in accordance with the instructions given in this manual. It is the customer's responsibility to ensure the compatibility of any other package they choose to use.

Warning Symbols

Throughout this manual the following symbols may be used where applicable to denote any particular hazards or areas which should be given special attention:



Note

This symbol highlights anything which would be of particular interest to the reader or provides extra information outside of the current topic.



Important

When this is shown there is potential to cause harm to the device due to static discharge. The components should not be handled without appropriate protection to prevent such a discharge occurring.



Caution

This highlights areas where extra care is needed to ensure that certain delicate components are not damaged.



Warning

DANGER OF INJURY TO SELF OR OTHERS

Where this symbol is present there is a serious risk of injury or loss of life. Care should be taken to follow the instructions correctly and also conduct a separate Risk Assessment prior to commencing work

Introduction

The Micron Gemini takes Tritech's Gemini Multibeam technology and blends it with a form factor of the Tritech Micron family to create the world's smallest Multibeam imaging sonar.

Having a 90° horizontal field of view, a 50m end range, and an update rate up to 20Hz with incredibly compact dimensions, the Micron Gemini can be used in applications where size is critical. This makes the Micron Gemini ideally suited to micro ROV/AUV's and applications where space is restricted or weight is critical, for example on diver helmets and pole mounted applications for Search and Recovery (SAR) operations.

All models can be fitted with an optional AHRS sensor to accurately determine 3D orientation.

The Micron Gemini communicates with Tritech's next generation integrated software suite Genesis using Ethernet or Tritech's advanced Serial Multibeam Protocol . The auxiliary port on the sonar allows for the daisy chaining of sensors including the Micron USBL Modem and Micron Echo Sounder. Advanced adaptive processing ensures that the most detailed image possible is generated regardless of range. This includes automatic switching between Compressed High Intensity Radar Pulse (CHIRP) and Continuous Wave (CW) modes of operation to maximize image definition.

Tritech's next generation integrated software suite Genesis is supplied with the Micron Gemini and is available from the Tritech website, supporting all Tritech's sensors. There is also a Windows® and Linux Software Development Kit (SDK) for the sonar to allow users to fully integrate the Micron Gemini into a customised system.

Technical Specifications

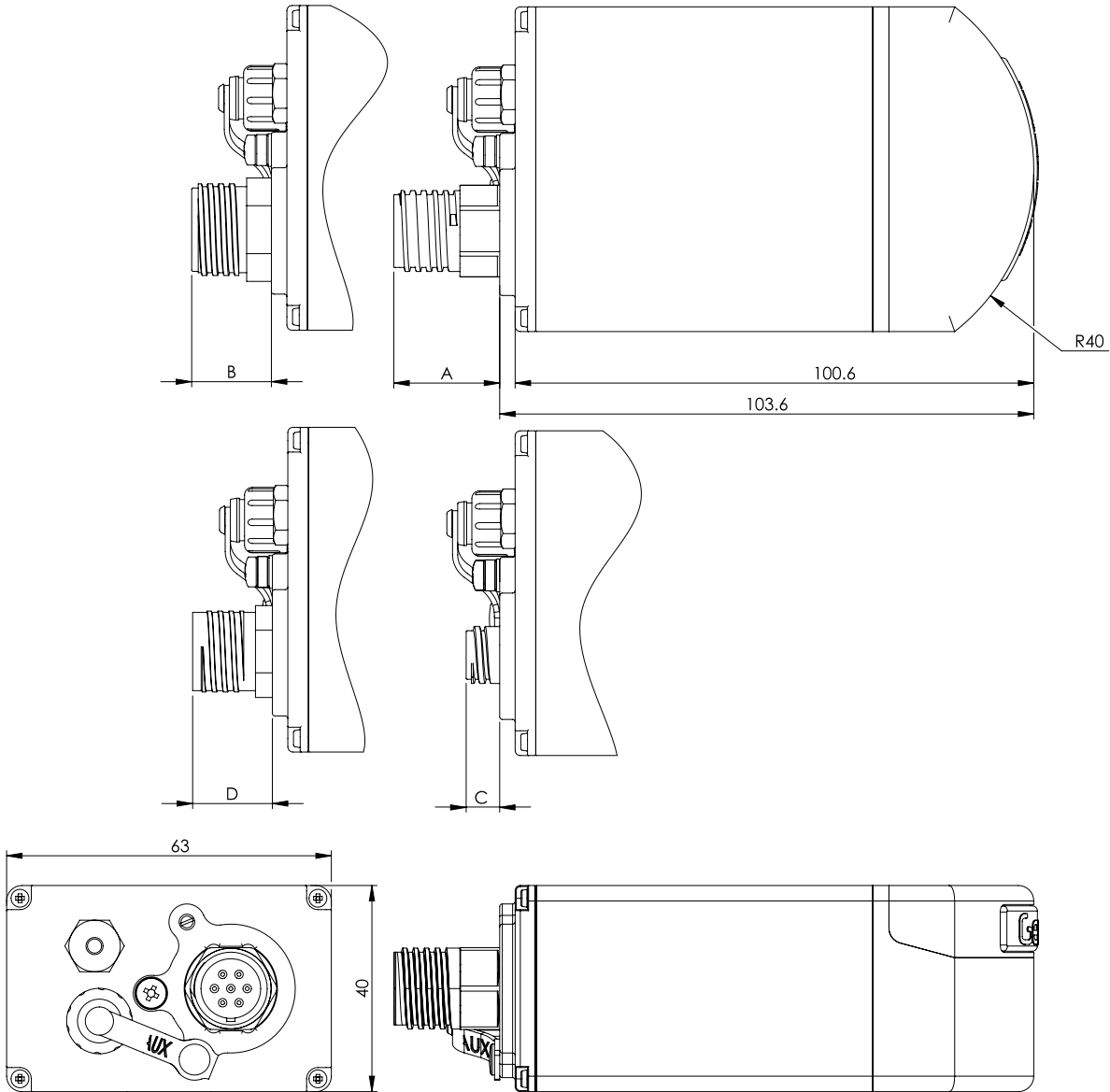

All dimensions are in mm, not to scale.

Main Port Connector	Configuration	Dimension	Comment
Aegir Marine MKS (W) BCR 07	A	20.5mm	Standard
Impulse MKS(W)-3L10-BCR	B	15.5mm	Standard
Tritech Micron	C	6.5mm	Standard
Impulse MKS(W)-307-BCR	D	15.5mm	Special Order

Acoustic Specifications	
Operating frequency	720 kHz
Angular resolution	2.34° acoustic, 0.7° effective
Range	0.2 m to 50 m
Number of Beams	128
Horizontal Beam Width	90°
Vertical Beam Width	20° ($\pm 10^\circ$ about horizontal axis)
Update rate (typical)	3 to 20 Hz (range dependant)
Range Resolution	8 mm (range dependant)
Mode of operation	Constant Wave (CW) or CHIRP
Speed of sound	Set via surface interface software

Integrated Sensor Specifications	
Depth Accuracy ¹	± 2 m
Temperature Accuracy ¹	± 2.0 °C
Heading/Bearing	2° RMS
Pitch/Roll	1.5° RMS (static)

Interface	
Supply voltage	12 to 48 VDC ²
Power requirement	8 W ³
Main port protocol	Ethernet (100Base-T) and / or Serial (RS232 or RS485)
Auxiliary port protocol	Serial (RS232 or RS485)
Connector type	Main: Impulse Titan™ or Trittech Micron Aux: Trittech Micron

Physical Specifications	
Depth Rating	300 m or 750 m
Weight in air	0.429 kg
Weight in water	0.240 kg
Temperature rating	-10 to 35 °C, (Storage -20 to 50 °C)

¹ Pressure Sensors are only available on the 300m Micron Gemini

² This does not cater for voltage drop in the cable.

³ The power consumption figures listed are average readings which include transients up to 29 W

Sonar Variants

The following shows the 3 different connector types, the communication protocols associated with them and depth ratings.

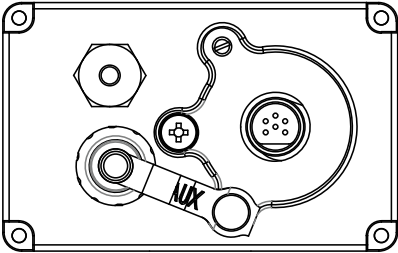
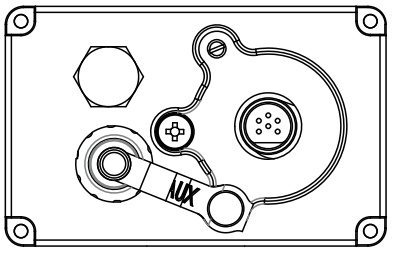
Communications	Tritech MICRON Connector Depth Rating	
	300m	750m
RS232/RS485	 <p>S12683</p>	 <p>S12686</p>

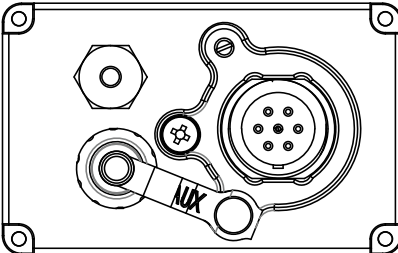
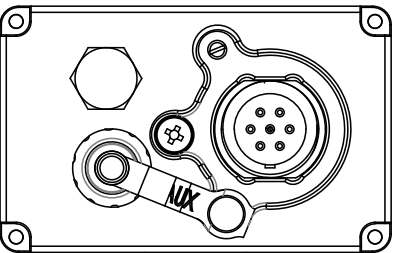
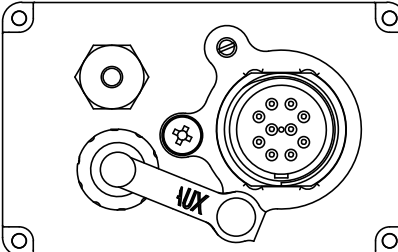
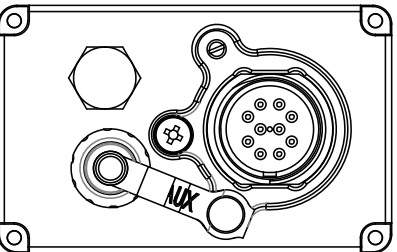
Communications	Impulse Titan™ Depth Rating	
	300m	750m
Impulse Titan™ MKS(W)-307 Ethernet ONLY	 <p>S12682</p>	 <p>S12685</p>
Impulse Titan™ MKS(W)-3L10 RS485 Or Ethernet	 <p>S12681</p>	 <p>S12684</p>

For pin out connector information, please see "Appendix A"



ONLY the 300m version has the pressure sensor.
AHRs can be fitted to both the 300m and 750m units.

Getting started

The following instructions are to help the user connect the system together for the first time and be able to successfully power on the unit. In order to prepare the system and test its functionality before mounting to a vehicle, the Micron Gemini requires either an Ethernet or Serial test kit (depending on user requirement).

If seeking support from Tritech, reference may be made to bench testing the unit on a short test cable



An example Micron Gemini test setup

Serial System Test Kit

The serial system test kit has different part numbers. This reflects the different mating tails required for the connector fitted to the Micron Gemini purchased. Please reference the serial number of the Micron Gemini and connector variant when in conversation with Tritech. The following serial system tests kits are available:

- **S11796–KIT1**– Tritech Micron test kit
- **S11792–KIT2**– Impulse Titan™ 3L10 test kit

In general, the serial system test kits includes the following parts:

S11670 - Gemini Power/Ethernet/Serial Break-out Assembly

A Gemini Power/Ethernet/Serial Break-out Assembly, enabling connection via a Serial to USB connection - for use in RS232/RS485 mode



S11346 - Gemini imaging sonar power supply unit

A power supply unit
(Country specific mains plug, specify at point of sale)



10m test cable

Souriau to Impulse Titan™ 3L10



or

Tritech Micron



Ethernet System Test Kit

The Ethernet system test kit has different part numbers. This reflects the different mating tails required for the connector fitted to the Micron Gemini purchased. Please reference the serial number of the Micron Gemini and connector variant when in conversation with Tritech. The following ethernet system tests kits are available:

- **S11624-KIT2-** Impulse Titan™ 307 test kit
- **S11792-KIT2-** Impulse Titan™ 3L10 test kit

In general, the Ethernet system test kits includes the following parts:

S11561 - Gemini Power/Ethernet Break-out Assembly

A Gemini Power/Ethernet Break-out Assembly, enabling an Ethernet connection via an RJ45 plug



S11346 - Gemini imaging sonar power supply unit

A power supply unit
(Country specific mains plug, specify at point of sale)



10m test cable

Souriau to Impulse Titan™ 3L10

or

Souriau to Impulse Titan™ 307



Assembling the Serial System

Step 1

Connect the breakout assembly to the 10 metre serial test cable, making sure to properly align the Souriau connector and its keyway.



Female connector of the breakout assembly and male connector of the test cable



A correctly mated Souriau communications cable

Step 2

Plug the connector end of the 10 metre serial cable into the Micron Gemini sonar, following the connection procedure for the appropriate connector.



An Impulse™ cable ready to be mated to the connector



A correctly mated Impulse™ cable

Step 3

Connect the power supply unit to the breakout assembly, making sure to properly align the Souriau connector and its keyway.



Female connector of the power supply unit and male connector of the breakout assembly



A correctly mated power cable

Step 4

Plug the USB connector on the serial breakout assembly into your computer, once this is done an orange LED will be dimly lit, indicating the system is ready to establish communications



A USB to serial converter indicating that it is establishing communications

Step 5

Once the system has established communication, the LED on the USB connector will be fully illuminated. The system is now ready to operate with the software, green LED's indicate the transmission and reception of data.

For more details of configuring the sonar parameters, please see the Genesis software manual and quick start guides available from the Trittech website see "Help & Support."



A USB to serial converter indicating that has established communications



Trittech Micron connections should only ever be made up finger tight.
Excessive force will damage the connector.

Assembling the Ethernet System

The assembly of the Ethernet system is similar to the process detailed in the Serial system

Step 1

Connect the Breakout assembly to the 10m Ethernet test cable, taking care to properly align the Souriau connector and its keyway.

Step 2

The connector on the Gemini and the Power Supply cable should be connected, similar to the instructions given for the Serial System setup (see "Assembling the Serial System").

Step 3

The Ethernet system requires the RJ45 connector plugged into your computer instead of the USB device.

If using the system for the first time or after installing new software. See "*Setting the computer IP address in Windows® XP*" or "*D - Setting the computer IP address in Windows® 7 or Windows® 10*" for information on setting up your computers Ethernet network port.

Installation

Communications Protocols

This section details communication information that should be taken into consideration prior to installation.

Serial

In order to achieve the maximum performance from the serial link it is recommended that the Trittech USB adapter is used. The Trittech USB allows Genesis and the Gemini to automatically negotiate to the maximum permissible baud rate for the line. The higher the baud rate the greater the bandwidth, resulting in an increase in the image update and quality.

The serial speeds available through the Trittech USB adapter are:

- 115200
- 230400
- 460800
- 921600
- 2Mbps
- 3Mbps
- 4Mbps



When using the Trittech USB adapter, Genesis will automatically detect the USB hardware plugged into the PC and populate Genesis with the Micron Gemini information.

RS232

The maximum permissible speed for RS232 is 921600 baud. This will only be achieved if the cabling is of a sufficient quality and below a certain length.

The maximum length of standard Trittech Micron cable that will support 921600 baud is 1 m. This means that you will not achieve the maximum RS232 baud rate with the supplied 10m Micron RS232 test cable.

RS485

This is the preferred serial communications protocol. It is recommended that a minimum speed 921600 baud is used for best overall performance.

Autocomms

The Tritech USB adapter supports auto negotiation of baud rate and communications protocol.

On start up the adapter will default to RS485. If RS232 is required, then you will need to left mouse click on the ID number of the Micron Gemini and select RS232 from the dropdown within the General tab.

This will only be an issue on links that do not allow RS485 communication, i.e. a fibre optic multiplexer

Serial Wiring

For wiring of the DE-9 connector please see *"USB to Serial Adapter Cable Options"*

Ethernet

The Ethernet adapter on the host PC must be in the same IP address range as the Gemini being attached. Using network comms allows multiple Geminis to be integrated using standard networking equipment.



The default IP address for a Gemini multibeam is 192.168.2.201 on subnet 255.255.255.0

Things to note:

- The Micron Gemini works on 100BASE-TX link.
- It is not recommended that you connect the Gemini units through a network hub. It is recommended that Gemini sonar units are connected using a network switch.



Connecting Multiple Ethernet Devices.

A network hub broadcast to all its ports and thus shares its bandwidth with each of the ports. If multiple devices are connected then the bandwidth allocation will be shared between devices, and so the bandwidth per device will drop. This will negatively affect the performance of the network.

A network switch keeps records of the MAC addresses of the devices connected so when a frame of data is received the data is sent to the appropriate port rather than broadcast. This means that each port on a network switch will have the maximum amount of bandwidth.

- Check your antivirus situation. Firewalls will see the data from the Gemini and may stop the broadcast message. Occasionally a firewall will allow the broadcast message but will stop the high data rate from imaging believing it to be a denial-of-service attack.

Electrical Installation

For electrical installation please see the connector pinouts in “*Appendix A*”

For the Micron connector a 1 metre test cable is available which is terminated to a D-Type Sub-Miniature connector, see “*Micron Test Cable - S11640 XXm*”.

General Connector Maintenance Guidelines

Mating surfaces should be lubricated with 3M Silicone Spray or equivalent, DO NOT GREASE. Connectors must be lubricated on a regular basis. Clean plugs and receptacles with soap and fresh water.



When attaching a connector make sure that both connector and socket are completely dry. Any water trapped in the connection could result in an electrical short.

Unused connectors must have a blanking cap fitted prior to immersing in water. Failure to do this will cause permanent damage.

If using alcohol or IPA to clean out the connector take care that it does not come into contact with any other part of the sonar.

Ground Fault Monitoring

The power supply within the Gemini includes an electrically isolated DC-DC converter frontend. There is a small capacitive connection between the isolated ground and the sonar chassis which should not noticeably affect any impressed current Ground Fault Indicator (GFI) equipment.

Power



Never try to make the Gemini work down a long cable by increasing the PSU output voltage above 48V DC.



Power should only be supplied to the Gemini through the MAIN port. The AUX port power is supplied via pass through from the MAIN port.



The Gemini PSU that is supplied with the Gemini system is intended for INDOOR USE ONLY and should not be placed in a position where it could get wet.

Cable Lengths and Voltage Drop

The voltage drop on a cable is a result of the surface area of the cable core and as such the resistance. The higher the resistance on the cable the higher the voltage drop and the higher input voltage.

For Trittech supplied cables the table below show the relationship between cable length and supply voltage.

Cable Type	Cable Length	Minimum Voltage (VDC)
Impulse Titan™MKS (S11352)	10m	12.6
	8m	12.4
	5m	12.0
Trittech Micron (S06020)	10m	15.5
	3m	13
	2m	12.4
	0.5m	12.3

For non Trittech cables the voltage drop can be measured by measuring the resistance of the cable and calculating or measuring the voltage at the sensor whilst it is powered.

Hardware Installation

To correctly mount the Micron Gemini, the blue Gemini logo/mould should be at the top, and the product label at the bottom.

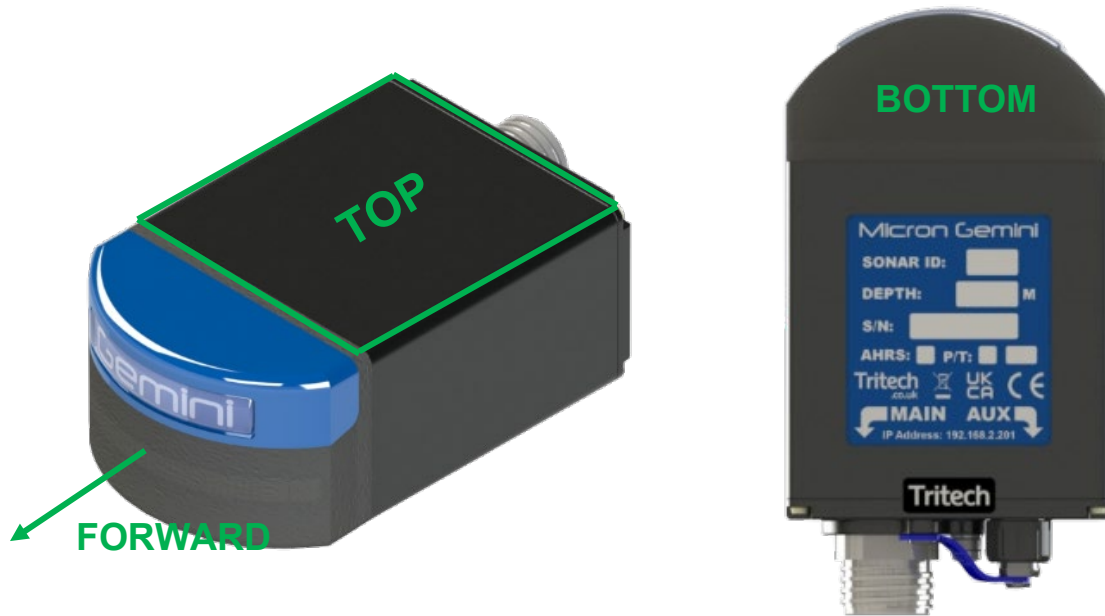

The transmit and receive elements are arranged along the horizontal axis which should be considered when mounting the sonar.

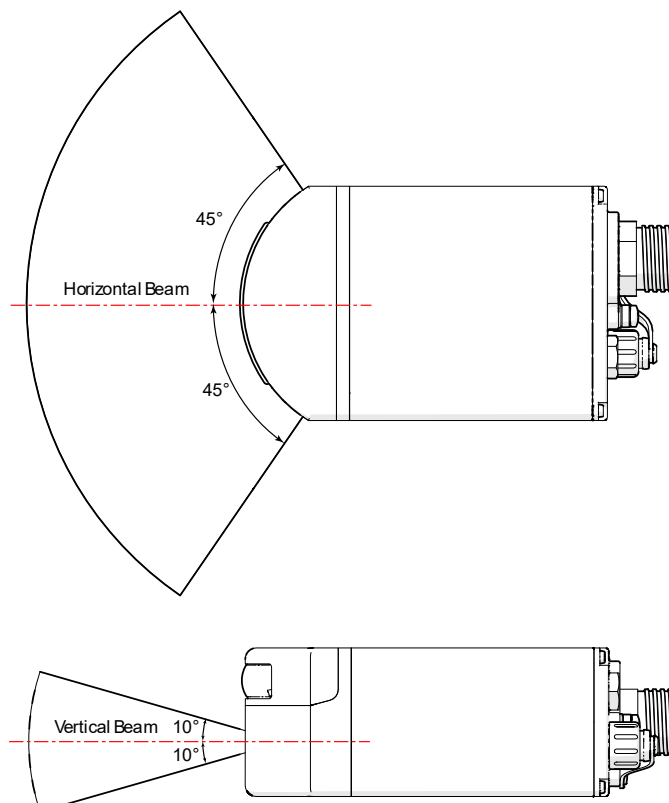

Any metallic clamps should be electrically insulated from the sonar body by either rubber or plastic strips or mounting brackets of at least 3 mm thickness and extending at least 3 mm beyond the clamp boundary to reduce any galvanic corrosion effect. Non-metallic clamps are preferable; if metallic clamps are used (especially if they are different in composition to the material used by the sonar) they should be painted or lacquered with at least two or three coatings.



Before connecting the Micron Gemini, it is recommended that the subsea cable connectors are examined for any damage, free of debris, clean and dry.



The outer case of the Micron Gemini is made of anodized aluminium. When deploying the sonar, direct contact with copper alloys such as brass or bronze should be avoided.

Mounting the Micron Gemini with AHRS

When fitting the Micron Gemini Sonar with AHRS to a vehicle or tool you may need to calibrate the AHRS sensor. See “AHRS Calibration” for details.

Installing the Micron Gemini using Tritech Mounts

There are multiple ways to mount the Micron Gemini due to its small size and versatility.

Tritech have produced Mounting Bracket Kits to enable the customer to adapt to their application, giving users the ability to angle the sonar at either 0° or 10° downward tilt.

There is also the Clamp Mounting Bracket which can be used where a quick release system may be more appropriate.



The mounts must first be fitted to the vehicle before the Micron Gemini is fitted to the mount.

Mounting using the Brackets

S11708 - Micron Gemini / 720im Mounting Bracket Kit

The kit comprises of the following components:

1	x	Micron Gemini / 720im Mounting Bracket Assembly	S11618 ASSY
4	x	M4 x 12 screws	S11772
4	x	M4 Nyloc nuts	S01159
4	x	8-32 x 1/2" screws	S11771
4	x	8-32 x 1/2" Nyloc nuts	S11775
1	x	Metric Allen key	S11774
1	x	Imperial Allen key	S11773

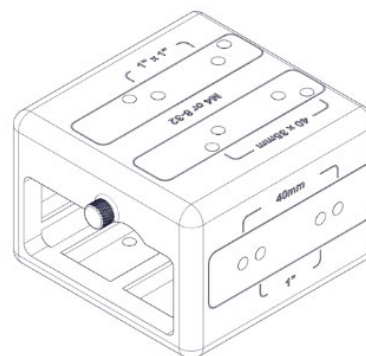

The Sonar Mounting Bracket allows the user to securely mount the Micron Gemini within a protective shell via a captive screw. The bracket utilises both imperial and metric fittings to enable the user to fit to their vehicle.

S11709 - Micron Gemini / 720im 10° Bracket Adapter Kit

The kit comprises of the following components:

1	x	Micron Gemini / 720im 10° Bracket Adapter Assy	S11702 ASSY
4	x	M4 x 12 screws	S11772
4	x	8-32 x 1/2" screws	S11771

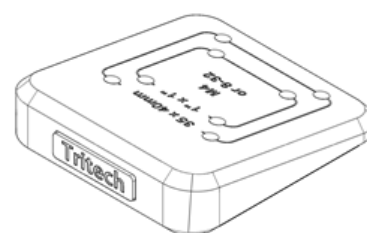

This allows the user to easily mount their mounting bracket at a 10° downward tilt.

Fixing the Sonar Mounting Bracket to your vehicle at 0°

The Sonar Mounting Bracket has both Metric and Imperial mounting hole footprints to allow easy mounting of the adapter. The following instructions assume that holes have been drilled in a mounting plate for your vehicle. See “Mounting Bracket Details” for the imperial and Metric holes layout.

Use either the Metric or Imperial spaced holes on the Mounting Bracket to fix to your vehicle or mount. There are Metric and Imperial screws provided to ensure an easy installation regardless of locale.



The image above is for example only. The pole mount adapter is used as the mating plate.

Fixing the Sonar Mounting Bracket to the 10° Adaptor

In the following examples the Micron Gemini is to be mounted via the 10° tilt adapter to a pre drilled mounting plate. See “Mounting Bracket Details” for the footprint for the holes required for mounting. The 10° Adapter has both Metric and Imperial mounting hole footprints to allow easy mounting of the adapter. The following instructions assume that holes have been drilled in a mounting plate for your vehicle. The example in this manual is given using Metric fitments.

Place the 10° adapter onto the vehicle or mounting plate with the Trittech logo facing the forward direction of the sonar, then use 4 of mounting screws in the required mounting holes. **The 10° adapter needs to be fitted first as the bracket covers the fixing holes**



You are now left with a fitted 10° adapter and the mounting bracket.



Align the mounting holes that you want to use then fit the mounting bracket as shown onto the 10° adapter.



Mounting the Micron Gemini into the Bracket

Insert the Micron Gemini as shown into the mounting bracket, making sure that the sonar is facing the correct way up. See the start of “Hardware Installation” for sonar orientation.



Align the Sonar mounting hole with the captive screw and fasten by turning clockwise. The captive screw is shown located above the main connector.



The captive screw is shown above the connector unfastened.



A Micron Gemini securely mounted inside the Mounting Bracket.

Mounting the Micron Gemini into the Clamp Mounting Bracket

The clamp mounting bracket allows the user to quickly mount and dismount a Micron Gemini to their vehicle.

The clamp mount bracket also allows you to fit the Micron Gemini at a 10° downward tilt.

To mount the Micron Gemini onto the clamp follow the instructions below.

The photo shows the clamp bracket and the Micron Gemini needed for mounting the system to your vehicle.



Place the Micron Gemini in the clamp bracket. In general, you would want to position the clamp centrally on the Micron Gemini body. Lining up the end of the lever with the front of the Micron Gemini, where the sides meet the front of the transducer is a good guide.



Move the lever all the way to the back to lock off the mount. The Micron Gemini is now ready to connect its cable.

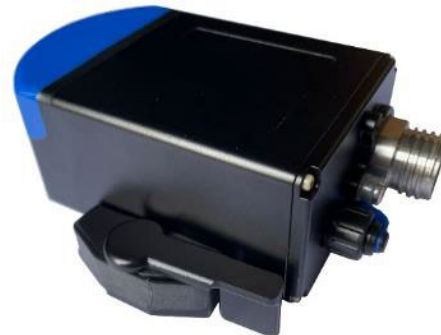

Inodive Mounting Options

For Inodive mounting options please see the *Pole Mount System Manual (0742-SOM-00003)*

Installing the Micron Gemini onto a Pole Mount System

Tritech International Ltd have also created ancillary systems to allow users to Pole Mount a Micron Gemini.

This methodology would be perfect for rapid deployment and imaging of an area where ROV access can be limited, or inappropriate.

S11938 Micron Gemini / 'im' - Pole Mount System

The kit comprises of the following components:

- 1 x Gemini DB - Pivot & Pole Mount Assembly S11745
- 1 x Gemini DB - 22mm Pole Assembly 0.5m S11836³
- 1 x Micron Gemini / 'im' - ROV Mount Assembly S11937

S11937 includes:

- 4 x S01159
- 2 x S04175
- 1 x S11618 ASSY
- 4 x S11772
- 1 x S11790
- 2 x S11861

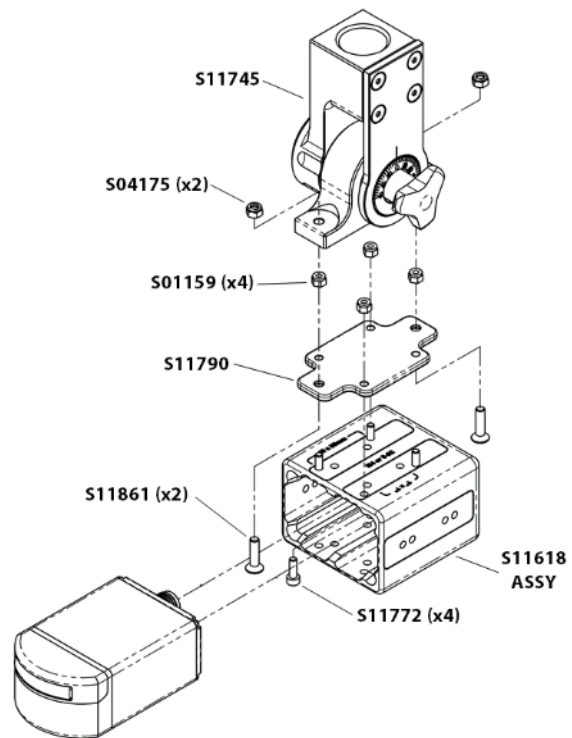

³ Alternative adapters available. See *Alternative Pole Adapters*.

The Micron Gemini Pole Mount Kit allows the user to mount the sonar onto a pole for manual deployment. The kit allows the sonar to be angled between $\pm 90^\circ$.

The Pole Mount Kit has been designed to be used in conjunction with the Sonar Mounting Bracket.

Alternative Pole Adapters

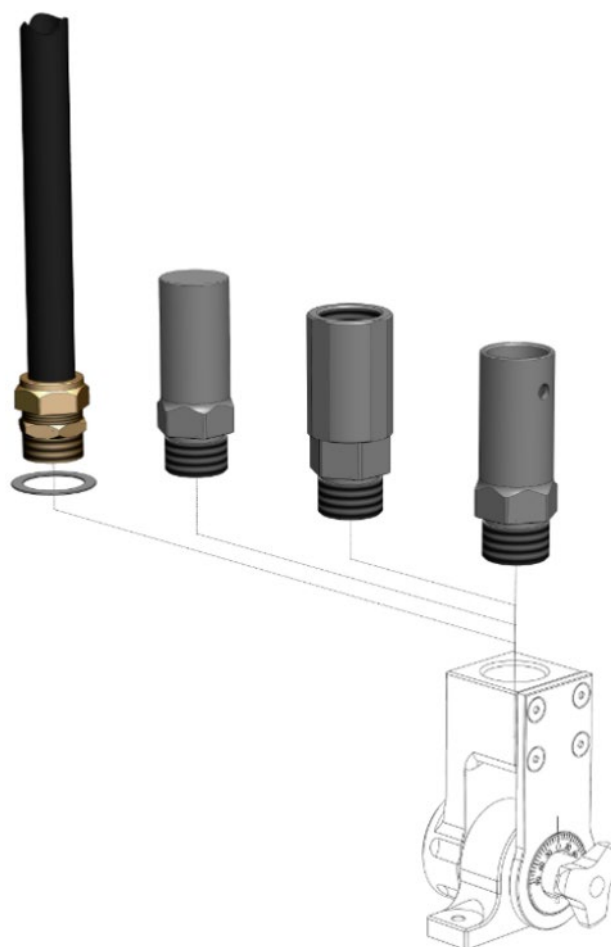

Items from left to right

- S11836 Utilises coupling on 22mm diameter carbon pole as per USBL system
- S11743 A blank adapter for customer adaption
- S11904 Supplied for US customers for coupling with a MINN KOTA® style Flexible Composite Shaft
- S11741 Configured to accommodate "sprung" pin engagement common to a range of 'Reach & Rescue' telescopic pole systems

S11836 & S11744 are supplied with all deployment pole mount brackets



Note

All mounts have a common interface thread which is 1½"-14 BSW (Whitworth)

Fixing the Sonar Mounting Bracket to your Pole Mount Kit

Secure the Micron Gemini Pole Mount Adaptor to the Gemini DB - Pivot & Pole Mount Assembly using the 2 x M5 x 20 screws and Nyloc nuts.

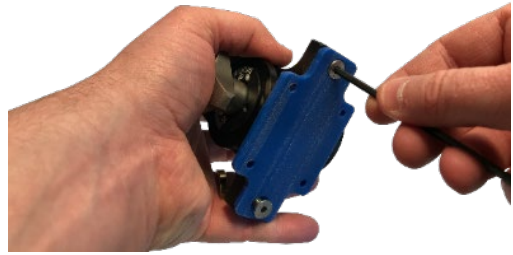

Secure the Micron Gemini Pole Mount Adaptor to the Sonar Mounting Bracket, using the 4 x M4 x 12 screws and Nyloc nuts provided with the Sonar Mounting Bracket.

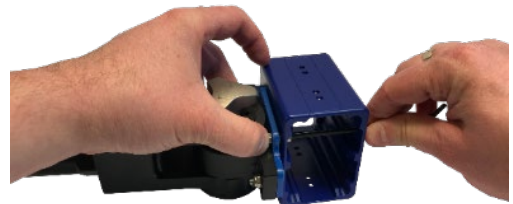

To adjust the tilt of the Micron Gemini, unscrew the knob on the Gemini DB - Pivot & Pole Mount Assembly

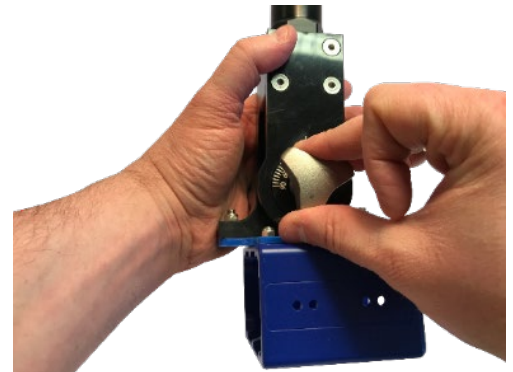

Next, adjust the mechanism to the desired angle. The angle can be set in intervals of 6°. Once set, tighten the knob.



The Pole Mount assembly is now complete and is ready for the Micron Gemini to be inserted into the Sonar Mounting Bracket.



Operation

Once fully connected to the PC (see “*Getting started*”) run the Genesis software using the desktop icon:



If connecting the Micron Gemini via an Ethernet connection, ensure that the computer IP has been set to the correct range to operate with the sonar. Please see “Setting the computer IP address in Windows® XP” or “D - Setting the computer IP address in Windows® 7 or Windows® 10” for details on this process.

Detailed instructions on the operation of the sonar in Genesis can be found in the Genesis software manual (0716-SOM-00001) and relevant quick-start guides.



The Genesis software suite is the only Trittech software package that the Micron Gemini sonar will operate under.

Pressure Sensor (300m only)

The pressure sensor is fitted as standard on the 300m Micron Gemini.

It can be identified from the label as the P/T (Pressure and Temperature) checkbox will be selected.

Within the software the depth and temperature will automatically be displayed on the far right of the sonar Plan Position Indicator.

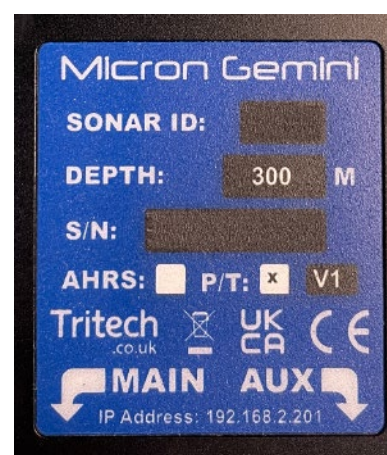

Detailed information can be found in the *Genesis software manual* (0716-SOM-00001).

AHRS (Attitude Heading Reference System)



The Micron Gemini AHRS needs to be run on Genesis version 1.7.3.76 or above

The AHRS within the Micron Gemini can be used to easily and accurately determine the 3D orientation of the sonar.

The artificial horizon presents itself in the Western “inside-out” style where the horizon moves with the sonar and the wings model is gyro stabilised. If the sonar is fitted upside down the AHRS will automatically compensate.

It can be identified from the label as the AHRS checkbox will be selected.

Unlike the Pressure sensor, the AHRS will not automatically populate into the software when the unit is attached (for Ethernet and Serial units using the Trittech USB). The unit will have to be set to Online within the Genesis software for the AHRS to start transmitting data. Once the sonar is Online, the sensor will show in a floating window which can be moved within the Genesis environment.

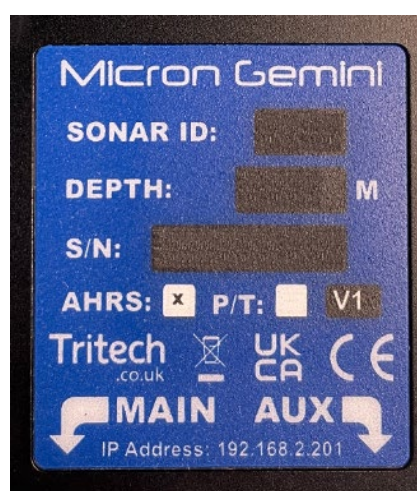

Detailed information can be found in the *Genesis software manual (0716-SOM-00001)*.

AHRS Calibration

The Gemini Micron AHRS has the AHRS calibrated at the factory. This is sufficient for the majority of situations.

There will be times whereby the local magnetic fields affect the heading readings. In this situation the AHRS can be calibrated. Local is defined as the equipment or tool that the sonar is mounted too. Not the local environment.

This calibration need only be carried out once, if the Micron Gemini is mounted on the same location within the vehicle or the hard/soft iron components on the vehicle do not change.

Calibrations should be carried out in an area with a homogenous magnetic field, without any ferromagnetic material nearby. If you are working on a large steel boat, then the sonar should be fitted to the vehicle and then calibrated in open water, away from the influence of the ships hull.



Calibration is not to be used to account for strong magnetic fields that do not move with respect to the sonar.

For example, calibrating the sonar by rotating the vehicle 360° next to a steel ship hull.

There are two calibration options available: 2D and 3D. Both do the same Magnetic Field Mapping however 2D is for deployment platforms which move more or less in one plane e.g. a boat or ROV, and 3D for platforms which can move freely through 360° in all axis.

The 2D calibration are sufficient for most customers applications.

If a 3D calibration is carried out but the sonar remains in the same plane or have limited pitch/roll then it will automatically save the data as a 2D calibration.

Detailed information can be found in the *Genesis software manual (0716-SOM-00001)*.

Maintenance

General guidance

Although the Gemini range is not field serviceable regular care and maintenance of the unit should be carried out.

The sonar body and endcap are protected from corrosion by the hard anodised passive surface film. This offers excellent protection in general operating conditions. However, without routine maintenance and in extended immersion in sea water, particularly at raised temperatures and salinity, the chlorides from the salt will start to attack this passive layer. To prevent such damage wash down the sonar post-dive to disperse contaminants such as salt deposits but care should be taken not aim high pressure water jets near sealing interfaces.

Particular care should be taken for units that use an o-ring seal on the connectors and blanking caps to ensure that these o-rings are seated properly and in good condition.

Regular visual inspection of the unit around the areas where salt build up can occur will help highlight any potential issues of corrosion and allow for corrective action to be undertaken before any integrity failure of the unit. The mechanical interface between the bulkhead connectors and housing elements should also be inspected.



It is recommended that Gemini units be returned to Tritech as part of a regular maintenance schedule. An annual return is highly recommended, but this can be lengthened, or shortened, by various factors:

- Frequency of use
 - The operating environment (i.e. salinity, temperature)
 - The presence of any galvanic action from dissimilar metals, or case voltages
-

After Use

After using the sonar head ensure it is washed down with fresh water and check the unit for any signs of obvious damage. Pay particular attention to the transducer face, pressure sensor (if fitted) and sacrificial anode. Once the unit is clean, dry thoroughly and place in storage container.

Equipment Storage

Make sure the unit is completely dry with no signs of moisture on any of the connectors. Fit all blanking plugs to the unit and pack into an appropriate storage container along with several pouches of silica gel.

Sacrificial Anode Information

There is a zinc alloy sacrificial anode fitted to the rear of the Micron Gemini which is intended to prolong its active life when submerged for long periods of time.

The lifespan of the anode itself will vary greatly depending on the conditions it is exposed to, so it may need to be changed on a relatively regular basis. As a minimum, Trittech International Ltd recommend replacing the anode every year with the sonar in regular use.

To replace the anode, follow the guidance below:

Remove the spent or damaged sacrificial anode from your sonar with a cross head screwdriver.



Open the replacement spare kit. Build the kit with the plastic washer nearest the sonar, anode and then the screw.



Fit to the sonar and tighten up the screw.



Spare anode kits can be purchased from Trittech International Ltd using the part number: S11882

Pressure Sensor Maintenance (300m only)

300m rated Micron Gemini sonars are fitted with a pressure sensor. This sensor requires regular maintenance to inhibit the opportunity for crevice corrosion and salt build up within the pressure sensor port.

To maintain the pressure port, first unscrew the seal screw with the S12759 Socket Tool provided (as illustrated).

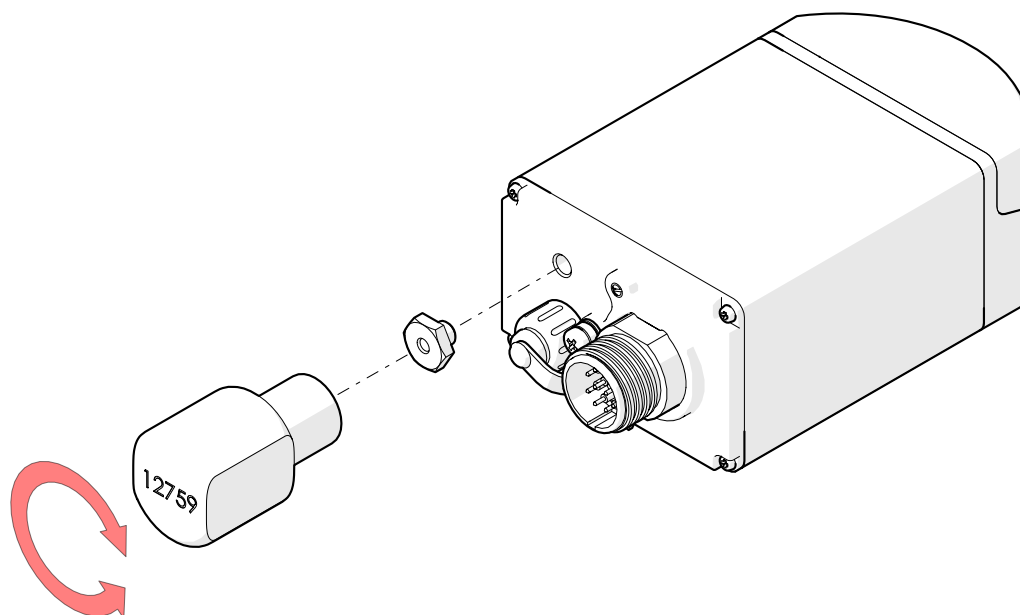

Check for evidence of any salt deposit and / or corrosion being initiated (i.e. pitting or crevicing).

Gently clean around the port with a damp soft cloth or cotton bud.

Check the O-Ring fitted to the PSI Seal Screw (S12754) for damage and if required unseat and clean around the periphery of the seal face.

Refit the Seal Screw using the Socket Tool; this requires '**finger tight**' torque only to ensure the face and O-ring are flush down to the endcap face.

Troubleshooting

The software reports that no sonars are detected

Ensure that the latest revision of Genesis software is running on your computer. Visit www.tritech.co.uk to download the latest version.

Check all cabling to the sonar and verify that it is powered correctly with appropriate voltage at the sonar.

For Ethernet systems: Check that the correct cable is in use, this needs to be a cable of at least Cat5e standard. If the sonar has successfully established a link then the problem will be with the network settings on the PC.



Ethernet connection requires Cat5e cable for the entire cable run (max 80m) – lengths of untwisted cable must be kept to an absolute minimum. Some firewalls have been known to cause this issue. Contact the network administrator for advice if the sonar is connected to a network where disabling the firewall would present a security risk.

Genesis crashes as soon as the Micron Gemini is detected

Without a Micron Gemini connected, run Genesis then select [Help] then [About] and note the OpenGL driver version detected - it should be at least version 2.1. If this is not the case, update the graphics drivers present on the computer.

For **Windows® OS**: Ensure that the file system is not corrupted by launching a `cmd.exe` window with Administrative privileges then use the `sfc/scannow` command. This will analyse and correct any issues.

Sonar goes offline while operating out of water

The sonar head outputs heat to the body casing (using it as a heatsink) which is dissipated to the surrounding water during normal operation. In order to protect the internal electronics from damage due to overheating a thermal cut off will shut down the sonar if it gets too warm. It will be necessary to allow the unit to cool down before it will operate again. The unit should not be operated out of water for extended periods.

Sonar is present but will not ping

Ensure that you have OpenGL version 2.1 or greater installed.

For Ethernet systems: Check your network settings on the PC. Typing `route print` into the command line will show the PC routing table. The sonar and PC must be on the same subnet and the PC's routing table needs to be set up so that packets are routed correctly to the sonar.

If the sonar is receiving ping requests, then the IP address of the PC will appear in the `Connected IP Address` field in the advanced settings page of the software. If the sonar is connected to the PC then the most likely cause is particularly bad packet loss on the network between sonar and PC.



The sonar will only respond to ping requests from IP addresses on the same subnet as the sonar. Some firewalls have been known to cause this issue. To view the computers routing table type `route print` from the command line.

For Serial systems: When using the Trittech International Ltd USB adapter, ensure that the Connected LED is fully illuminated and that the Tx and Rx LEDs are flashing. If there is no LED activity, use the `Device Manager` in Windows® to ensure the USB drivers have been correctly installed.

If using a **direct serial connection**: ensure that the COM Port has been correctly assigned in the Genesis software and that the baud rate has been set to at least **115200**. Check that the wire cores have been correctly terminated.

Update rate is slow and there are sometimes large gaps between pings

Check that there is no other software, or service, that is intensively using the network connection. Run the PC or laptop with just the Gemini software and verify that the unit's performance has been improved. There may be noise induced onto the Ethernet cables, be sure to route these as far away as practicable from noise sources.

The Micron Gemini will not connect using RS232 on my Multiplexer

The issue may lie with the type of connection that you have and the way that the Micron Gemini Autocomms works. See the

Autocomms section for more details. This situation will occur mostly in multiplexer systems that utilise fibre optics, rather than a wired copper connection.

The Micron Gemini always starts in RS485 mode, this ensures that in most cases the Micron Gemini will be picked up when plugged into the computer with the Trittech USB. However, on fibre optic systems the connection is not transparent and so the protocol needs to be matched. If the fibre channel is set for RS232 the multiplexer will not accept the initial RS485 negotiation and so a base connection to the Micron Gemini cannot be established.

To get the Micron Gemini to work in this scenario you will need to add the Micron Gemini manually to Genesis, and then manually set the comms protocol in the device settings to RS232 and 115200 baud.

The Micron Gemini should then communicate with the software. Once you have a stable connection to can set the software to negotiate faster serial rate for the line.

Appendix A - Connector Details

This appendix covers the pinouts for the various connectors and the associated wiring detail for the Micron Gemini Sonar and its peripherals.



Application of reverse supply voltage to the unit or supply voltage across any of the communication connections may lead to equipment damage not covered under the warranty conditions.

Tritech Micron

Main Port

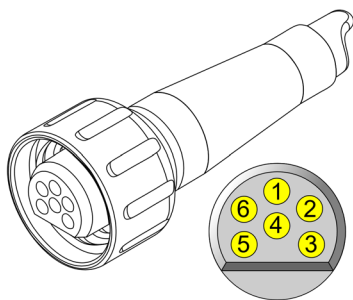
Connector Face View	Pin	Function	Cable Core Colour
	1	RS485 A RS232 Tx	Yellow
	2	RS485 B RS232 Rx	Blue
	3	+ V DC	Red
	4	0V DC	Black
	5	RS232 GND	Green
	6	Shield	Cable Sheath
<i>Cable colours correct as of 17/03/22</i>			

Aux Port

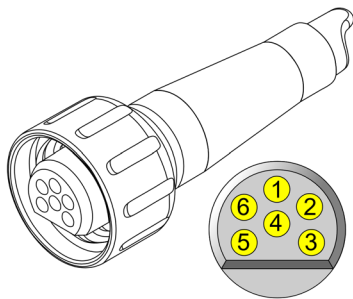
Connector Face View	Pin	Function	Cable Core Colour
	1	RS485 B RS232 Rx	Yellow
	2	RS485 A RS232 Tx	Blue
	3	+ V DC	Red
	4	0V DC	Black
	5	RS232 GND	Green
	6	Shield	Cable Sheath
<i>Cable colours correct as of 17/03/22</i>			



Cable core colours may change. The best practice when using the cable colours as reference is to double check against the connector pin out diagram supplied with them. Failure to check cable wiring may result in damage to the unit.



Tritech Micron connections should only ever be made up finger tight.
Excessive force will damage the connector.

Micron Test Cable - S11640 XXm

ITEM NO.	QTY.	PART NUMBER	DESCRIPTION
1	1	05975 XM	MICRON CONNECTOR TAIL
2	1	04162	Heatshrink 9.5mm - 50mm
3	1	06020	Micron cable
4	1	06803	9w D-Sub Back Shell Assembly
5	1	01849	9w D-Sub Straight Socket
6	1	05892	24AWG, 7-0.2mm stranded conductor - Red
7	1	07296	4mm Banana Plug - Red
8	1	05891	24AWG, 7-0.2mm stranded conductor - Black
9	1	07297	4mm Banana Plug - Black
10	1	00366	22AWG, 16-0.2mm stranded conductor - Green / Yellow
11	1	07298	4mm Banana Plug - Green
12	1	00017	6.4 / 3.2 Heatshrink - 110mm

NOTES:
 THE 'XM' SUFFIX OF THE PART NUMBER INDICATES OVERALL CABLE LENGTH IN METRES, ALL OTHER DIMENSIONS IN MILLIMETRES
 CUT UNCONNECTED CONDUCTORS FLUSH AT CABLE ENDS
 CONNECT SCREEN FROM MICRON CONNECTOR TAIL (ITEM 1) TO EARTH WIRE / BANANA PLUG (ITEMS 10 / 11) AND MICRON CABLE (ITEM 3) TERMINATING AT D-SUB METALIZED BACK SHELL (ITEM 4)
 CHANGES @ 02:
 CONTACTS 2 (Tx / COMM A) & 3 (Rx COMM B) ON 9w D-SUB SWAPPED

6w MICRON CONNECTOR	SIGNAL	CONDUCTOR COLOUR	9w D-SUB SOCKET	BANANA PLUG
1	RS232 Tx / RS485 A	YELLOW	2	N/C
2	RS232 Rx / RS485 B	BLUE	3	N/C
3	+V DC	RED	N/C	RED
4	0V DC	BLACK	N/C	BLACK
5	RS232 GND	GREEN	5	N/C
6a	EARTH/CABLE SHIELD	GREEN / YELLOW	B2	GREEN
6b	EARTH/CABLE SHIELD	SCREEN	SHELL	N/C

Q2	26/04/23	AS DWG	AE	GT	AE
ISSUE	DATE	DCN No	ISSUED BY	RVD BY	AUTH BY
DRAWING CHANGES					

TOLERANCES (EXCEPT AS NOTED)	DIMENSIONS IN MILLIMETERS UNLESS OTHERWISE STATED	DWG BY	AE 30/03/2017
FRACTIONS .X ±0.1mm .XX ±0.05mm .XXX ±0.02mm	DO NOT SCALE IF IN DOUBT ASK	RVD BY	BD 03/04/2017
ANGULAR CONCENTRIC ±0.05mm	A3	AUTH BY	AE 03/04/2017
MACH FINISH OR NOTED CLEAN BURRS & BREAK CORNERS 16	MATERIAL N/A	REF. No	11640 XM
		TU PART No	11640 XM
		ORIGINAL SCALE	1:1

Tritech International Limited
 8000 Mill Hill Road, Mill Hill, Overton, Leamington Spa, CV32 9JF
 Tel: +44 (0)2476 35000 Fax: +44 (0)2476 35005

TITLE 0114 CABLE ASSEMBLIES
 REF. No 05975 MICRON TO 9w D-SUB & BANANA PLUGS
 COPYRIGHT AND DESIGN RIGHTS RESERVED

DWG No 0114-MSA-00068-02 SHEET No 1 OF 1

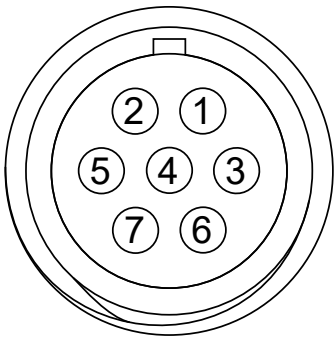
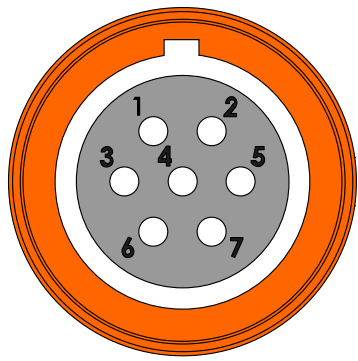

Impulse Titan™

MKS(W)-307

Bulkhead Face View	Pin	Function	Cable Face View
	1	0V DC	
	2	+V DC	
	3	Screen	
	4	Ethernet Rx +	
	5	Ethernet Rx -	
	6	Ethernet Tx +	
	7	Ethernet Tx -	

MKS(W)-3L10

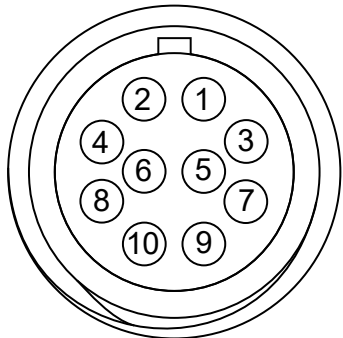
The cable view below shows a fully wired Impulse Titan™ 3L10 cable. This covers RS485 and Ethernet combinations.

Bulkhead Face View	Pin	Function	Cable Face View
	1	Screen	
	2	+V DC	
	3	N/C	
	4	0V DC	
	5	RS485A	
	6	RS485B	
	7	Ethernet Tx +	
	8	Ethernet Rx +	
	9	Ethernet Tx -	
	10	Ethernet Rx -	



The **S11792-KIT2** test kit contains the combined Ethernet and RS485 whip (S11799 Xm/S11800 Xm) and test cable (S11801 Xm/S11802 Xm). These cables cannot support RS232 as there is no RS232 GND core available in the cable.

Impulse Titan™ MKS(W)-3L10 Cable Options

To clarify the communication options available from the Trittech International Ltd supplied Impulse Titan™ 3L10 cables, the options have been detailed below:

Cable Part Number	Description	Communication Available	
		Ethernet	RS485
S11711 XXm	Impulse MKS(W)-3L10-CCP PWR/ E'NET Whip	✓	✗
S11712 XXm	Impulse MKS(W)-3L10-CCP-RA PWR/E'NET Whip	✓	✗
S11729 XXm	MKS(W)-3L10-CCP to UTS6JC1412P E'NET Test Cable	✓	✗
S11730 XXm	MKS(W)-3L10-CCP-RA to UTS6JC1412P E'NET Test Cable	✓	✗
S11799 XXm	Impulse MKS(W)-3L10-CCP PWR/ E'NET/485 Whip	✓	✓
S11800 XXm	Impulse MKS(W)-3L10-CCP-RA PWR/ E'NET/485 Whip	✓	✓
S11801 XXm	MKS(W)-3L10-CCP to UTS6JC1412P E'NET/485 Cable	✓	✓
S11802 XXm	MKS(W)-3L10-CCP-RA to UTS6JC1412P E'NET/485 Cable	✓	✓

Souriau UTS6JC124S – S09126

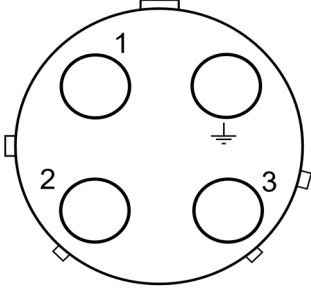
Connector Face view		Pin	Function
		1	0V DC
		2	+V DC
		3	n/c
		earth	Screen

USB to Serial Adapter Cable Options

USB to Serial Test Cable - S11942 1m

This is designed to replicate a standard PC serial port connection and as such is a DE-9M connector.

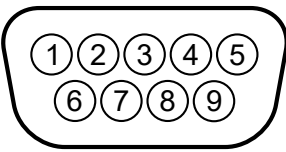
DE-9M Face View	Pin	Tritech USB Function	Tritech USB Cable Core Colour
	2	Rx/A	Red
	3	Tx/B	Black
	5	Signal GND	Brown

Serial to USB VideoRay Pro4 Test Cable - S11859 1m

This is designed connect the surface computer (USB socket) to the AUX connection of a VideoRay Pro4 surface control box.

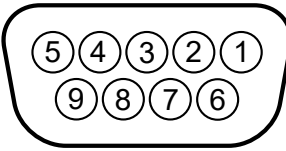
DE-9F Face View	Pin	Tritech USB Function	Tritech USB Cable Core Colour
	2	Rx/A	Red
	3	Tx/B	Black
	5	Signal GND	Brown

Appendix B - Mounting Bracket Details



Drawings are not to scale. Dimensions in millimetres (mm) unless otherwise stated.

Sonar Mounting Bracket - S11708

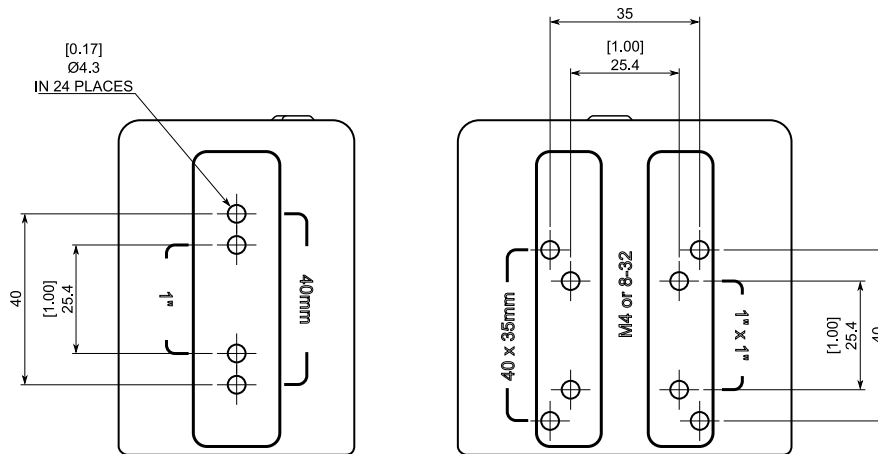

HOLE PATTERNS REPLICATED ON OPPOSITE SURFACES

Mounting Bracket 10° Adaptor - S11709

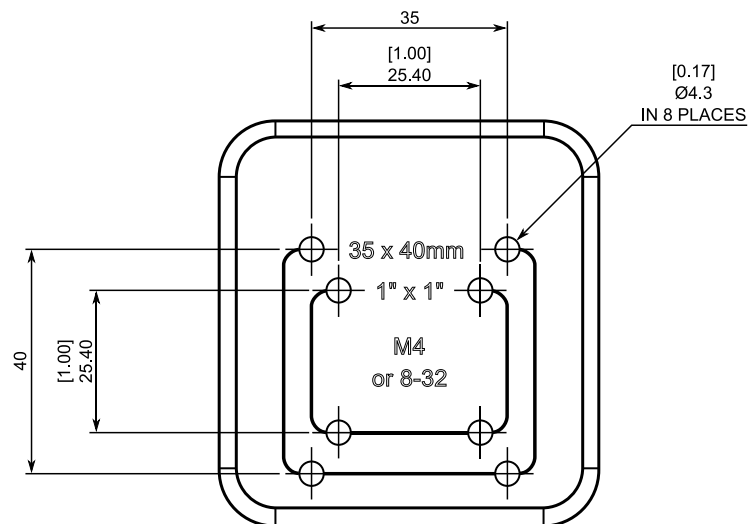

Pole Mount Adapter - S11790

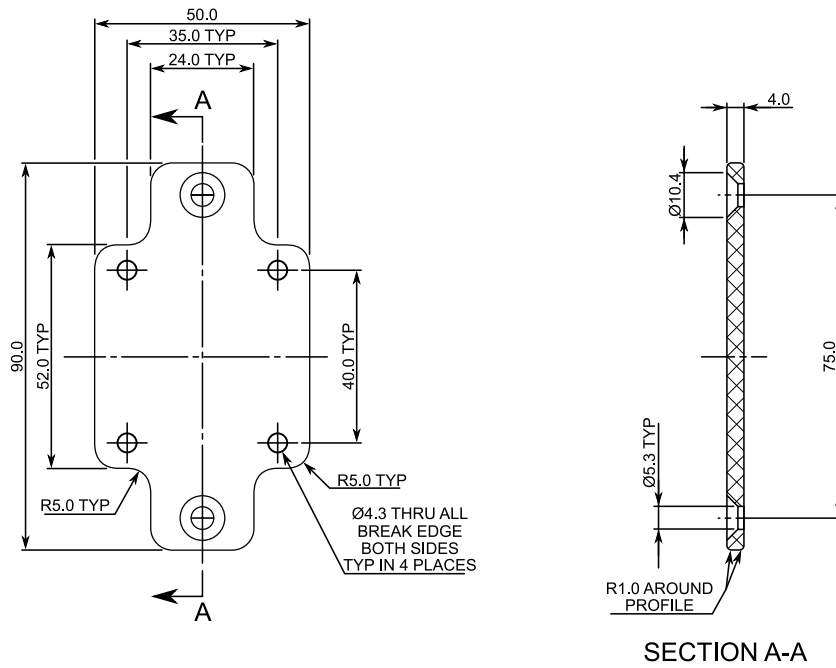

Clamp Mount Adapter - S11846

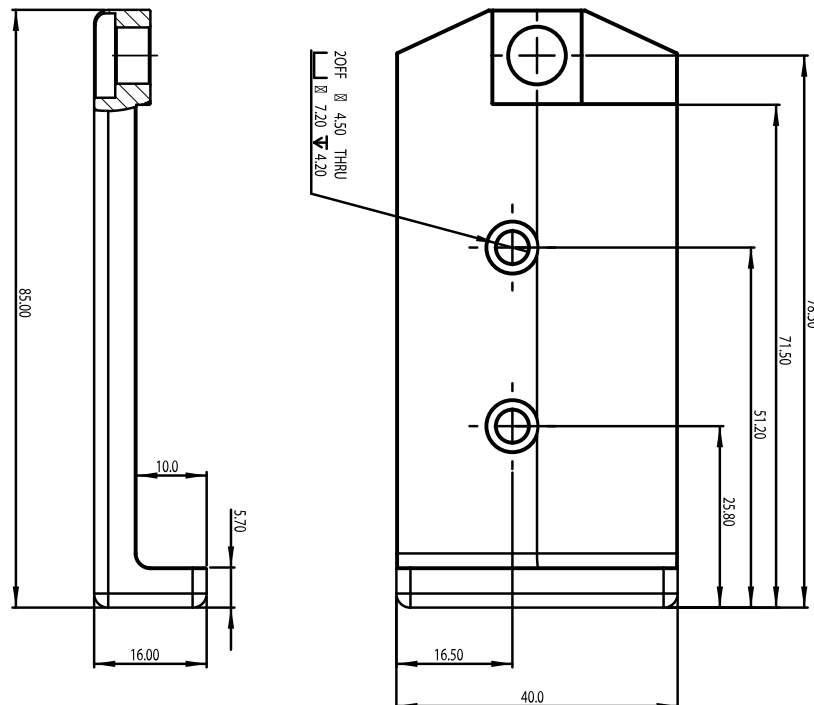

Only the footprint of the baseplate shown in this dimensional drawing.

Appendix C - Setting the computer IP address in Windows® XP

The following instructions apply to a computer running Windows® XP, though the sequence for other operating systems will be similar.

If the computer is connected to a network already, disconnect it from that network.

From the [Start Menu] select [Control Panel]. From the [Control Panel] Explorer window that opens, double click on [Network Connections]. From the list of available network connections that opens, double click on the [Ethernet connection] which will be used to connect to the Gemini head.

Click the [Properties] button on the dialog which opens. This will open a dialog which looks like this.



Scrolling the [This connection uses the following items] box will reveal an item titled [Internet Protocol (TCP/IP)].

Click this item to select it, and then press the [Properties] button. The following dialog should open.

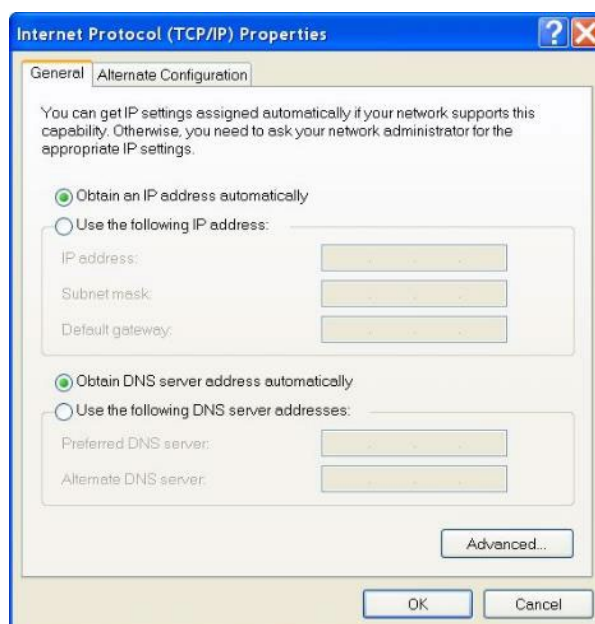

Make a note of the settings as currently used by the computer; these will be needed to restore the computer to any existing network. Refer to the appropriate section of this manual for the correct IP address to use.

The following screenshot shows the dialog after those changes have been made:

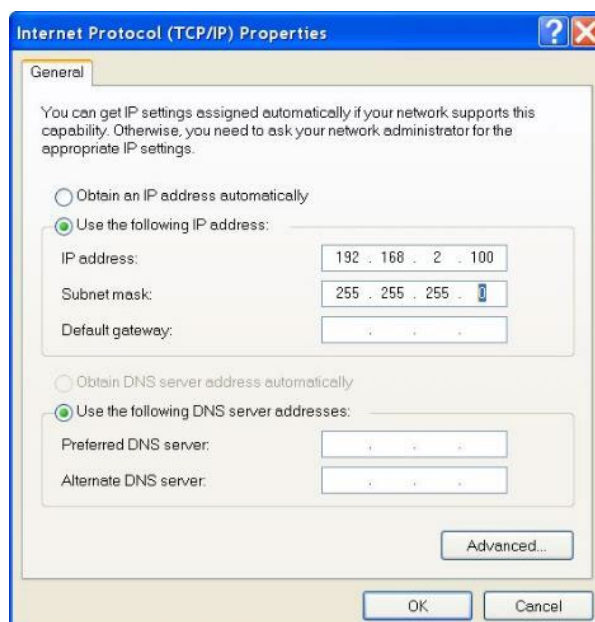

Appendix D - Setting the computer IP address in Windows® 7 or Windows® 10

The following instructions apply to a computer running Windows® 7 or Windows® 10, though the sequence for other operating systems will be similar. All screenshots are from a Windows® 7 installation.

Disconnect the computer from any existing network.

First click on the [Start Menu] and select [Control Panel].

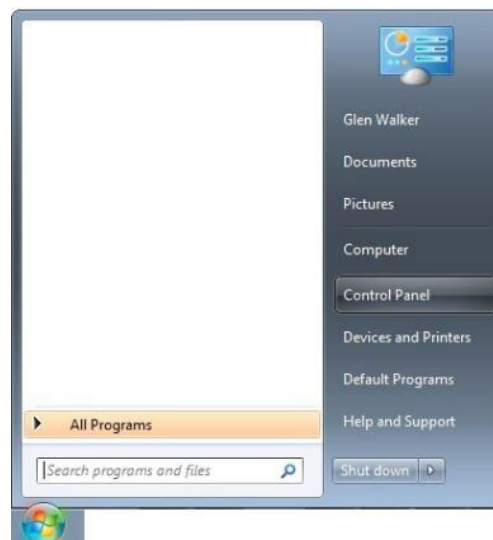

Under [Network and Internet] click on [View network status and task].



This will bring up the [Network and Sharing Center] which allows configuration of any networks on the computer. Click on [Change adapter settings] on the left-hand pane.



A list of attached network devices should now present itself. Find the one which the Gemini head is to be connected to and double-click on it.

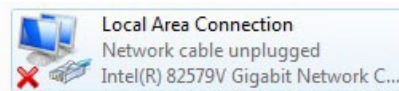

The [Local Area Connection] Properties dialog should be displayed. Find the entry labelled [Internet Protocol Version 4 (TCP/IPv4)], select it and then click on the [Properties] button.

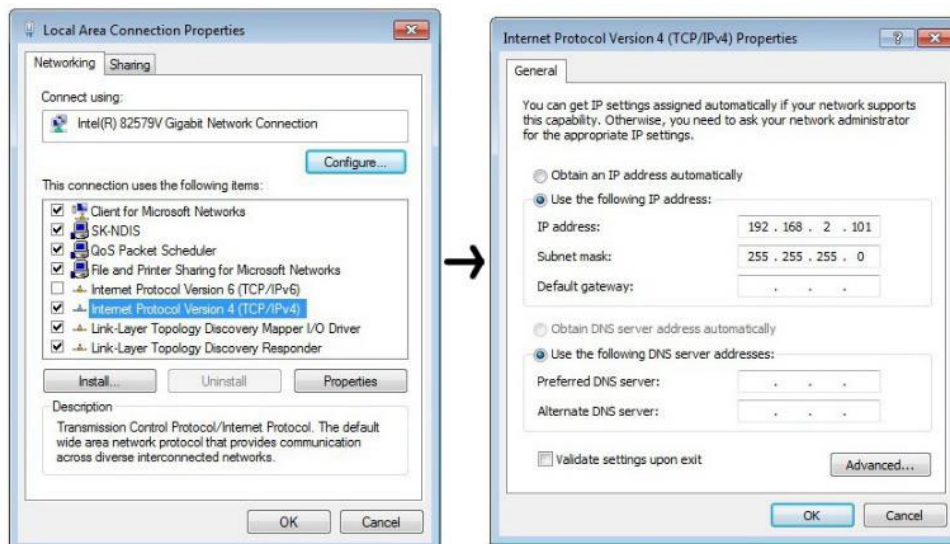

In the properties dialog which opens there will either be [Obtain an IP address automatically] or [Use the following IP address] selected. If an IP address is already present, make a note of it before changing any values since it will be needed if the computer is ever restored to the previous network. Refer to appropriate section of this manual for the correct IP addresses to use.