

Gemini 1200ik

Product Manual

0746-SOM-00002-05



© Trittech International Ltd

The copyright in this document is the property of Trittech International Ltd. The document is supplied by Trittech International Ltd on the understanding that it may not be copied, used, or disclosed to others except as authorised in writing by Trittech International Ltd.

Trittech International Ltd reserves the right to change, modify and update designs and specifications as part of their ongoing product development programme. All product names are trademarks of their respective companies.

Open Source License Statement: This product may include software code developed by third parties, including software code subject to the GNU General Public License Version 2 ("GPLv2"). We will provide upon request the applicable GPL source code files via CD-ROM or similar storage medium for a nominal cost to cover shipping and media charges as allowed under the GPL. This offer is valid for a 3 year period from first manufacture of this product.

General Public License ("GPLv2") Inquiries: Please direct all GPL inquiries to the following address:

Trittech International Ltd
Peregrine Road
Westhill Business Park
Westhill, Aberdeenshire
AB32 6JL, UK

Table of Contents

Warning Symbols	4
Help & Support	5
Introduction	6
General Overview.....	6
Technical Specifications	7
Installation	9
Communications.....	9
Electrical connection.....	9
Connector Maintenance Guidelines	9
Ground Fault Monitoring	9
Power	10
Connector Pin-Out	10
Software Version	11
Hardware installation	12
Installing the Sonar head	12
Mounting Options.....	13
General System Operation	14
Deck Test Equipment	14
Sonar Operational Notes	15
Dual Frequency Options	15
Maintenance	16
After using the sonar	16
If storing the sonar for extended periods.....	16
Regular maintenance	16
Sacrificial Anodes	17
How to change the Anode.....	17
Troubleshooting	18
The software reports that no sonars are detected	18
Sonar goes offline while operating on deck.....	18
Sonar is present but will not ping	18
Velocimeter reports unrealistic speed of sound.....	19
Sonar reports "Out of Water" when submerged.....	19
Appendix A – Setting the computer IP address in Windows®	20

Warning Symbols

Throughout this manual the following symbols may be used where applicable to denote any particular hazards or areas which should be given special attention:

**Note**

This symbol highlights anything which would be of particular interest to the reader or provides extra information outside of the current topic.

**Important**

When this is shown there is potential to cause harm to the device due to static discharge. The components should not be handled without appropriate protection to prevent such a discharge occurring.

**Caution**

This highlights areas where extra care is needed to ensure that certain delicate components are not damaged.

**Warning**

DANGER OF INJURY TO SELF OR OTHERS

Where this symbol is present there is a serious risk of injury or loss of life. Care should be taken to follow the instructions correctly and also conduct a separate Risk Assessment prior to commencing work.

Help & Support

First please read this manual thoroughly (particularly the Troubleshooting section, if present). If a warranty is applicable, further details can be found in the Warranty Statement, 0080- STF-00139, available upon request.

Tritech International Ltd can be contacted as follows:



Mail

Tritech International Ltd
Peregrine Road
Westhill Business Park
Westhill, Aberdeenshire
AB32 6JL, UK



Telephone

+44 (0)1224 744111



Email

support@tritech.co.uk



Website

www.tritech.co.uk

Prior to contacting Tritech International Ltd please ensure that the following is available:

1. The Serial Numbers of the product and any Tritech International Ltd equipment connected directly or indirectly to it.
2. Software or firmware revision numbers.
3. A clear fault description.
4. Details of any remedial action implemented.



If the product has been used in a contaminated or hazardous environment you must de-contaminate the product and report any hazards prior to returning the unit for repair. Under no circumstances should a product be returned that is contaminated with radioactive material.

The name of the organisation which purchased the system is held on record at Tritech International Ltd and details of new software or hardware packages will be announced at regular intervals. This manual may not detail every aspect of operation and for the latest revision of the manual please refer to www.tritech.co.uk.

Tritech International Ltd can only undertake to provide software support of systems loaded with the software in accordance with the instructions given in this manual. It is the customer's responsibility to ensure the compatibility of any other package they choose to use.

Introduction

General Overview

The Gemini 1200ik is a dual frequency 2D imaging sonar offering the opportunity to choose the benefit of either longer acoustic ranges or higher resolution imagery between the Lower and Higher frequency channels. It is a multibeam sonar, offering a 120° field of view on both the Low frequency and High frequency channels with update rates of up to 65Hz (30Hz typical) giving rapid feedback to the user.

The system consists of the Gemini sonar head(s) with Genesis control and display software.

The sonar can be supplied as 'Single Port' or 'Dual Port' models. The 'Dual' Port option connects and operates the same way as a 'Single Port' unit but with a secondary 'Aux Port' connection which allows additional RS232 sensors to be connected and the option of a TTL synchronisation signal.

Technical Specifications

The Gemini 1200ik Sonar is available in two depth ratings, 500m (previously 350m) and 1000m. Whilst the width and side profile of the sonars are the same, the deeper rated (1000m) model has updated top and bottom covers resulting in an increase in height. The basic dimensions for the sonars are shown below:

350m (legacy) & 500m Depth Rating

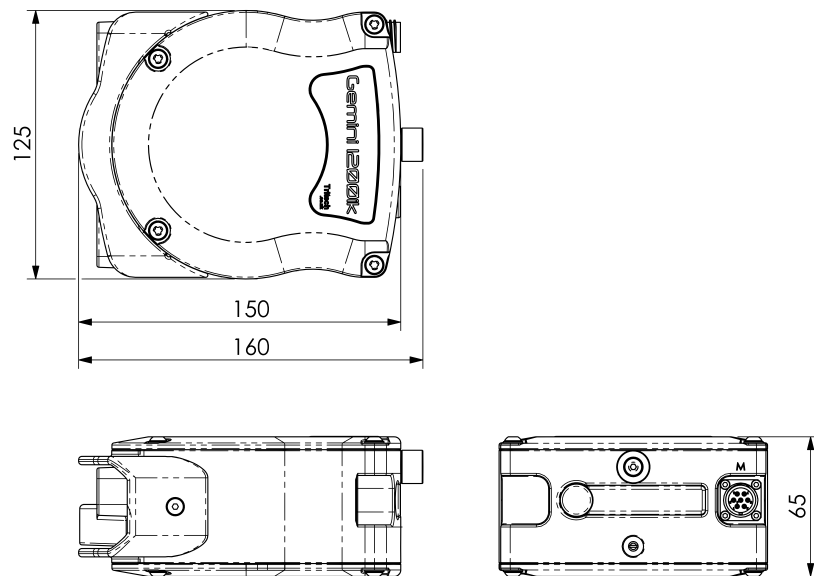

1000 m Depth Rating

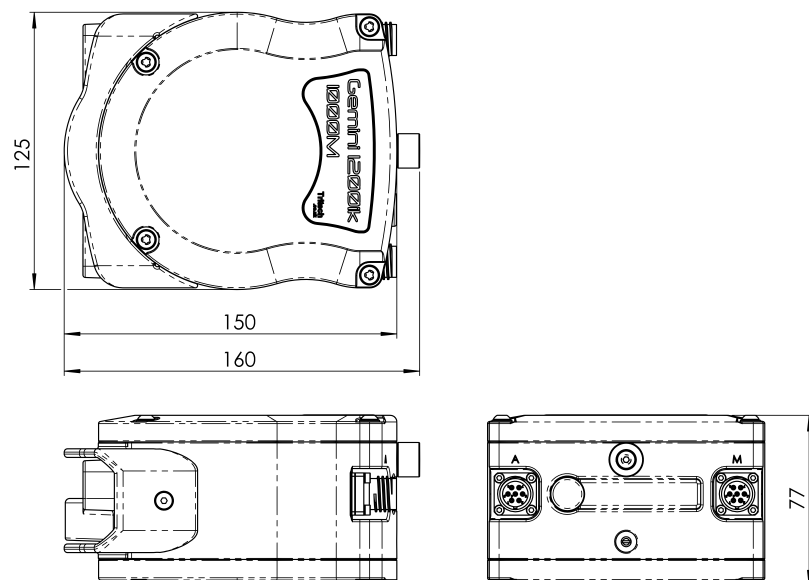

Drawings not to scale. Dimensions in millimetres (mm) unless otherwise stated.

Acoustic Specifications		
	Low Frequency	High Frequency
Operating frequency	720 kHz	1200 kHz
Angular resolution	1.0° acoustic, 0.25° effective	0.6° acoustic, 0.12° effective
Range	0.1 m to 120 m	0.1 m to 50 m
Number of beams	512	1024
Horizontal beamwidth	120°	65° or 120°
Vertical beamwidth	20° (± 10° about horizontal)	12° (± 6° about horizontal)
Range resolution	4 mm	2.4 mm
Update rate	5 – 65 Hz (range dependent)	
CHIRP support	Yes	
Speed of Sound	Integrated Sensor	

Interface Specifications	
Supply voltage	19 V to 74 V DC
Power requirement	9.5 W to 27 W (range dependant) ¹
Main port protocol	Ethernet 100BASE-TX
Auxiliary port (optional)	RS232, TTL in, pass-through power (2.5A max)
Connector type	Impulse MKS(W)-307-FCR

Physical Specifications			
Depth rating	350m	500m	1000m
Weight in air	1.46 kg		2.03 kg
Weight in water	0.5 kg		0.92 kg
Temperature rating	-10°C to 35°C(operating), -20°C to 50°C (storage)		

¹ The power consumption range quoted is for a standalone unit and does not include cable losses.

Installation

Communications

Communication to the sonar uses a 4 wire Ethernet. When using an Ethernet connection it should be noted that the Gemini Sonar can fully utilise a 100BASE-TX link while returning the sonar data. If the Gemini Sonar is to share an Ethernet link with other high bandwidth devices, such as video cameras, it is recommended that the 100BASE-TX devices share a gigabit (or faster) link to the surface to reduce possible network congestion.

Electrical connection

Please refer to *Technical Specification (Connector)* for details on the connector fitted and the appropriate communication mode supported. A cable whip supporting Ethernet communications can be supplied. The other end of this cable whip should be terminated with a suitable connector for the user application.

Connector Maintenance Guidelines

Mating surfaces should be lubricated with 3M Silicone Spray or equivalent. **Do not apply oil based greases.** Connectors must be lubricated on a regular basis. Clean plugs and receptacles with soap and fresh water.



When attaching a connector make sure that both connector and socket are completely dry. Any water trapped in the connection could result in an electrical short.

If the Gemini has two connection ports then the unused connector must have a blanking cap fitted prior to immersing in water. Failure to do so will cause permanent damage not covered under the warranty terms.

Ground Fault Monitoring

The power supply within the Gemini includes an electrically isolated DC-DC converter front-end. There is a small capacitive connection between the isolated ground and the sonar chassis which should not noticeably affect any impressed current ground fault indicator (GFI) equipment.

Power

Please see *Technical Specification* for details on the power requirements for the sonar.



Never try to make the Gemini work down a long cable by increasing the PSU output voltage above 74V DC.



The Gemini PSU that is supplied with the Gemini system is intended for INDOOR USE ONLY and should not be placed in a position where it could get wet

Connector Pin-Out

Bulkhead view	Main port		Aux port	
	Pin	Function	Pin	Function
	1	0 V DC	1	0 V DC
	2	+ V DC	2	+ V DC
	3	Shield/Chassis	3	Shield/Chassis
	4	Ethernet Rx+	4	TTL +
	5	Ethernet Rx-	5	RS232 GND / TTL GND
	6	Ethernet Tx+	6	RS232 Tx
	7	Ethernet Tx-	7	RS232 Rx



Power should only be applied to the MAIN port of the Gemini. The AUX port, if fitted, provides an un-regulated pass-through power supply taken directly from the MAIN port input supply.

Software Version



The Gemini 1200ik is only compatible with Genesis software V1.7.3.76 and above.

The latest Genesis software can be downloaded from the Support Software section of the Trittech website www.Trittech.co.uk. The latest release of Genesis will contain the latest revision of firmware for the Gemini Sonar and is the only mechanism to allow customer updates.

Hardware installation



Although the sonar head is rugged, it should be handled with care, particularly the connector and receiver/transmitter elements. The plastic guard fitted to the unit will not be able to protect the sonar against significant impacts.

Installing the Sonar head

The sonar should be mounted with the receiver element on the top. The transmit and receive elements are centred about the horizontal axis which should be considered when mounting the Sonar.

Any metallic clamps should be electrically insulated from the sonar body by either rubber or plastic strips or mounting brackets of at least 3 mm thickness and extending at least 3 mm beyond the clamp boundary to reduce any galvanic corrosion effect. Non-metallic clamps are preferable; if metallic clamps are used (especially if they are different in composition to the material used by the sonar) they should be painted or lacquered with at least two or three coatings.



When deploying the Gemini 1200ik, alloys containing copper such as brasses or bronze should be avoided.



1. Sound Velocity Probe
2. Receiver Elements
3. Transmitter Elements

Mounting Options

The sonar must be held in place securely when fitted on a vehicle. Standard orientation is top & bottom however the sonar image can be flipped within software should the sonar be mounted inverted. The Gemini 720/1200ik Sonar Mount Assembly shown here can be purchased as a mounting accessory kit from Tritech.

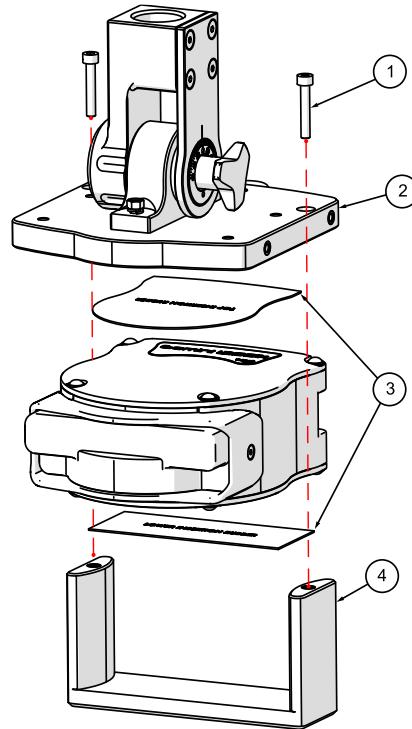

Associated part numbers and descriptions are given in the table below:

Gemini ik Sonar Mount Assembly 350m & 500m - S11935 ¹			
Item No	Qty	Part Number	Description
1	2	S06272	M5x30mm SKT Cap Screw A4
2	1	S11736	Gemini ik Sonar Mount - Top Plate
3	1	S11755	Gemini ik Sonar Mount - Insertion Rubber Kit
4	1	S11737	Gemini ik Sonar Mount - Brace

Gemini ik Sonar Mount Assembly 1000m – S13117 ¹			
Item No	Qty	Part Number	Description
1	2	S06272	M5x30mm SKT Cap Screw A4
2	1	S11736	Gemini ik Sonar Mount - Top Plate
3	1	S11755	Gemini ik Sonar Mount - Insertion Rubber Kit
4	1	S13100	Gemini ik 1000 m Sonar Mount - Brace



General System Operation

Deck Test Equipment

Tritech recommend and can supply a stand-alone set of test equipment that can be used for:

- Initial setup and verification of the sonar
- Familiarisation of the sonar and software
- Use of the sonar separate to the vehicle
- Fault diagnosis of any sonar, connection or software issues

The deck test items can be supplied separately, or as a kit and consist of the following:

Gemini ik Deck Test Kit Part No. S11624-Eth-Kit2		
Part No. *	Description	
S11561	Gemini Power and Ethernet Break-Out Assembly	
	Y splice cable to connect to a Gemini Power Supply and an RJ45 Ethernet connection	
S11346	Gemini Sonar Power Supply	
	Internal use power supply with country specific AC connection cable.	
S11624 10M	Gemini ik Sonar 10 metre Deck Test Cable	
	Impulse MKS(W)-307-CCP-RA to 12w Souriau Test Cable 10m	

* Contents and specification of test kits may change due to design and engineering development, specific or specialised test kits can be sourced from Tritech sales or you normal vendor.



Tritech recommend the use of a deck test kit for fault-finding and giving a reliable direct connection to the sonar for firmware updates. If available, Tritech Support may ask that the sonar be connected directly to the surface PC using the test cables to isolate any vehicle communication effects.

Sonar Operational Notes

When using a dual frequency 1200ik multibeam sonar there are some operational factors which must be considered in order to make best use of the dual channel capability of the sonar.

Dual Frequency Options



720 kHz Low Frequency Operation

The sonar has a 120° horizontal field of view at +/- 10° about the horizontal axis (20° in total). In this mode of operation the sonar can image targets up to its maximum range however the definition of targets will be lower than when used in its higher frequency mode.



1200 kHz High Frequency Operation

The sonar has a 120° horizontal field of view at +/- 6° about the horizontal axis (12° in total) which is a slightly reduced vertical beam-width when compared with the lower frequency channel. This mode will produce higher definition images compared with the lower frequency mode. In high frequency (1200kHz) mode, the user has the option of switching to using just a 65° sector which will double the update rate when compared to utilising the full 120° sector scan.

High frequency (HF) 1200 kHz will work best up to 40m range scale providing the user with higher resolution images than if operating on the lower (LF) 720 kHz channel. Due to acoustic principals the effectiveness of 1200 kHz operation drops of significantly at range. When operating in auto frequency mode the sonar will automatically switch to LF operation above 40m range.

For more details on Genesis software operation please refer manual available from the support section of the Trittech website www.tritech.co.uk.

Maintenance

After using the sonar

Make sure that after using the sonar head that it is washed down with fresh water and check the unit for any signs of obvious damage. Pay particular attention to the transducer head and free any organic matter which has become trapped. Once the unit is clean; dry thoroughly and place in storage container.

If storing the sonar for extended periods

Make sure that the sonar is completely dry (if necessary, leave to dry in air before stowing). Pack into storage container along with several pouches of silica gel.

Regular maintenance



It is essential to have a regular maintenance schedule so that any defects arising from corrosion or erosion can be spotted early and corrected before they cause severe damage to the unit. It is recommended that the unit is annually serviced and can be returned to Trittech International Ltd for this purpose.

Although the Gemini range is not field serviceable regular care and maintenance of the unit should be carried out. Ensuring that the electrical connectors are clean and free of corrosion will aid in preserving the working lifespan of the unit. Particular care should be taken for units that use an O-ring seal on the connectors and blanking caps to ensure that these O-rings are seated properly.

Regular visual inspection of the unit around the areas where salt build up can occur will help highlight any potential issues of corrosion and allow for corrective action to be undertaken before any integrity failure of the unit. The areas around the Transmitter and Receiver array should be inspected, as well as the VOS sensor. The mechanical interface between the bulkhead connectors and housing elements should also be inspected.

As part of a regular visual inspection cycle it is recommended that the front panel of the Gemini be removed in order to clean around the front elements of the sonar.



Do not deploy the Gemini without the cover being attached to the unit.

It is recommended that Gemini units be returned to Trittech as part of a regular maintenance schedule. An annual return is highly recommended, but this can be lengthened, or shortened, by various factors:

- Frequency of use
- The operating environment (i.e. salinity, temperature)
- The presence of any galvanic action from dissimilar metals, or case voltages

Sacrificial Anodes

The Gemini ik sonar is fitted with a sacrificial anode at the rear of the unit. The body of the sonar is made from Aluminium and the health and functioning of the Sacrificial Anode is vital to preventing corrosion to the body and pressure sealing areas while the sonar is submerged.

Tritech recommends the Anode is replaced as part of the regular maintenance every 12 months or when eroded to less than 50% of the original size.



Anode in good condition.

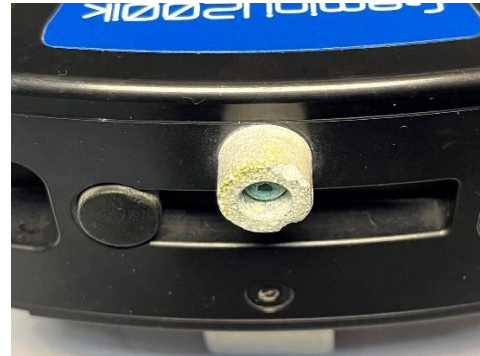

Used anode, approx. 80% of original size.



Submergence and use of the Sonar without an adequate and correctly fitted Anode may result in severe corrosion and damage to the sonar body not covered under the warranty terms.

How to change the Anode

Parts required:

2.5mm Hex Key

Gemini ik Anode Replacement Kit (Part No. S11793)

Loosen and remove the Hex Head Cap Screw from the back of the sonar and remove the old anode.

Replace with the new cap screw and Anode from the replacement kit.

Place the Nylon Washer between the Anode and the Sonar Body, and the Spring Washer between the Cap Screw and Anode.

Gently tighten the Cap Screw (finger tight) onto the Sonar Body.



Troubleshooting

The software reports that no sonars are detected

Ensure that the latest revision of Gemini software is running on your computer. Visit www.tritech.co.uk to download the latest version. Check all cabling to the sonar and verify that it is powered correctly with appropriate voltage at the sonar. Also check that the correct cable is in use, this needs to be a cable of at least Cat5e standard. If the sonar has successfully established a link then the problem will be with the network settings on the PC.



Ethernet connection requires Cat5e cable for the entire cable run (max 80m). Untwisted cable must be kept to an absolute minimum.

Some firewalls have been known to cause this issue. Contact the network administrator for advice if the sonar is connected to a network where disabling the firewall would present a security risk.

Sonar goes offline while operating on deck

The sonar head outputs heat to the body casing (using it as a heatsink) which is dissipated to the surrounding water during normal operation.

In order to protect the internal electronics from damage due to overheating a thermal cut-off will shut down the sonar if it gets too warm. It will be necessary to allow the unit to cool down before it will operate again.

The unit should not be operated out of water for extended periods.

Sonar is present but will not ping

Ensure that the latest revision of Microsoft® .NET™ framework has been fully installed onto your PC or laptop.

Check your network settings on the PC. Typing "route print" from the command line will show the PC routing table. The sonar and PC must be on the same subnet and the PC's routing table needs to be set up so that packets are routed correctly to the sonar. If the sonar is receiving ping requests then the IP address of the PC will appear in the "Connected IP Address" field in the advanced settings page of the software.

Check your anti-virus settings. Firewalls may see the data from the network and prevent the broadcast message. Occasionally a firewall may allow the broadcast message but stop the high data rate from the sensor believing it to be a denial-of-service attack. If this is the case, navigate to "Allowed Apps" in windows and add permissions to the firewall settings for Genesis Software.

If the sonar is connected to the PC then the most likely cause is particularly bad packet loss on the network between sonar and PC.

Velocimeter reports unrealistic speed of sound

This is often caused by bubbles forming on the metal faces at the rear of the sonar or within the slot at next to the VoS Sensor. This can happen if the sonar has been stationary for an extended period of time in a tank, moving the sonar to remove any bubbles should resolve the issue.

Sonar reports "Out of Water" when submerged

This is reported by Genesis when the VoS Sensor at the rear of the Sonar reports an out-of-range value for the speed of sound. This is typically caused by air bubbles or marine growth in the slot at the back of the sonar adjacent to the VoS Sensor. Once cleared, the sonar should return to normal operation.

When the sonar reports "Out of Water" the transmit transducer is powered down and the sonar will not ping. The receive circuit remains operational and will show background noise on the sonar display.

Appendix A – Setting the computer IP address in Windows®

The following instructions apply to a computer running Windows® 7, Windows® 10 or Windows® 11, though the sequence for other operating systems will be similar. All screenshots are from a Windows® 10 installation.

Disconnect the computer from any existing network.

First click on the [Start Menu], type “Control Panel” and select [Control Panel].

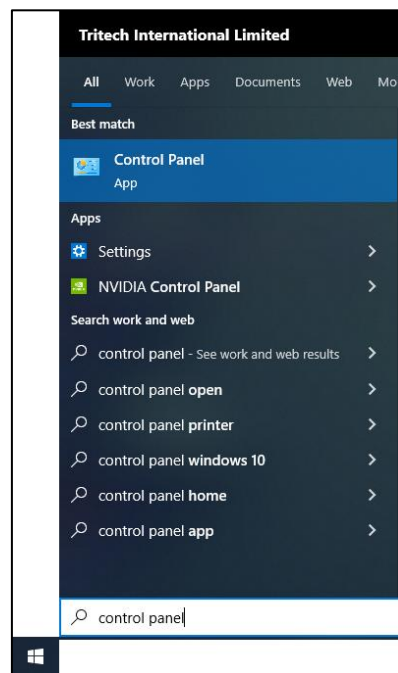

Under [Network and Internet], click on [View network status and tasks].

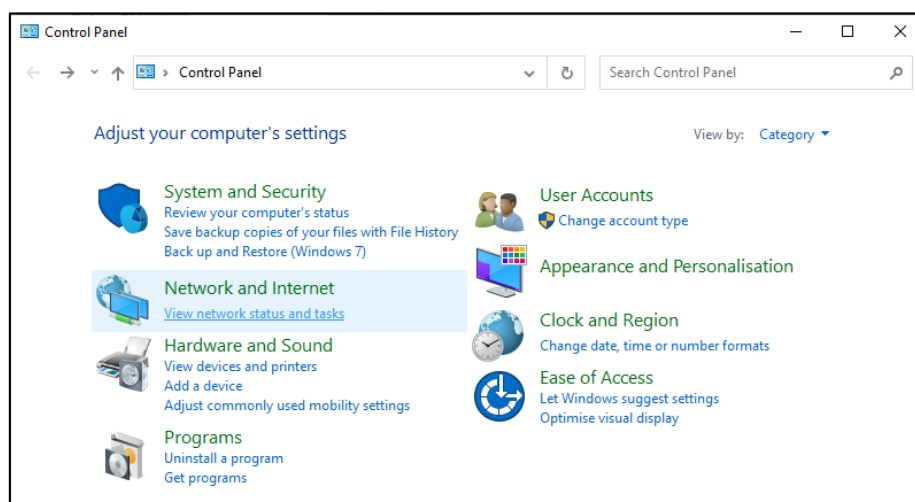

This will bring up the [Network and Sharing Centre] which allows configuration of any networks on the computer. Click on [Change adapter settings] on the left-hand pane.

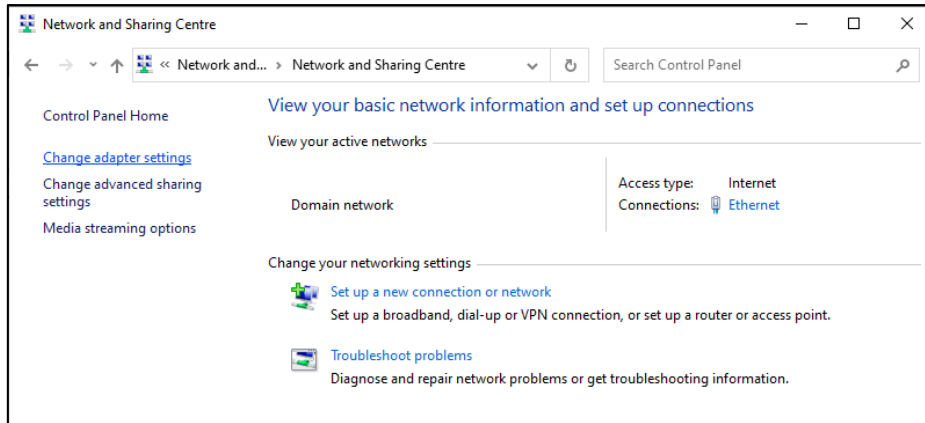

A list of attached network devices should now present itself. Find the one which the Gemini head is to be connected to and double-click on it. (In this example it is called “Ethernet”) Then click on [Properties] on the window that opens.

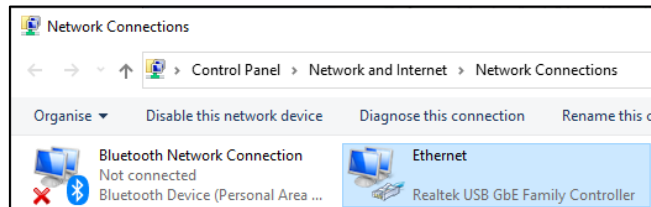

The [Ethernet] Properties dialog should be displayed. Find the entry labelled [Internet Protocol Version 4 (TCP/IPv4)], select it and then click on the [Properties] button.

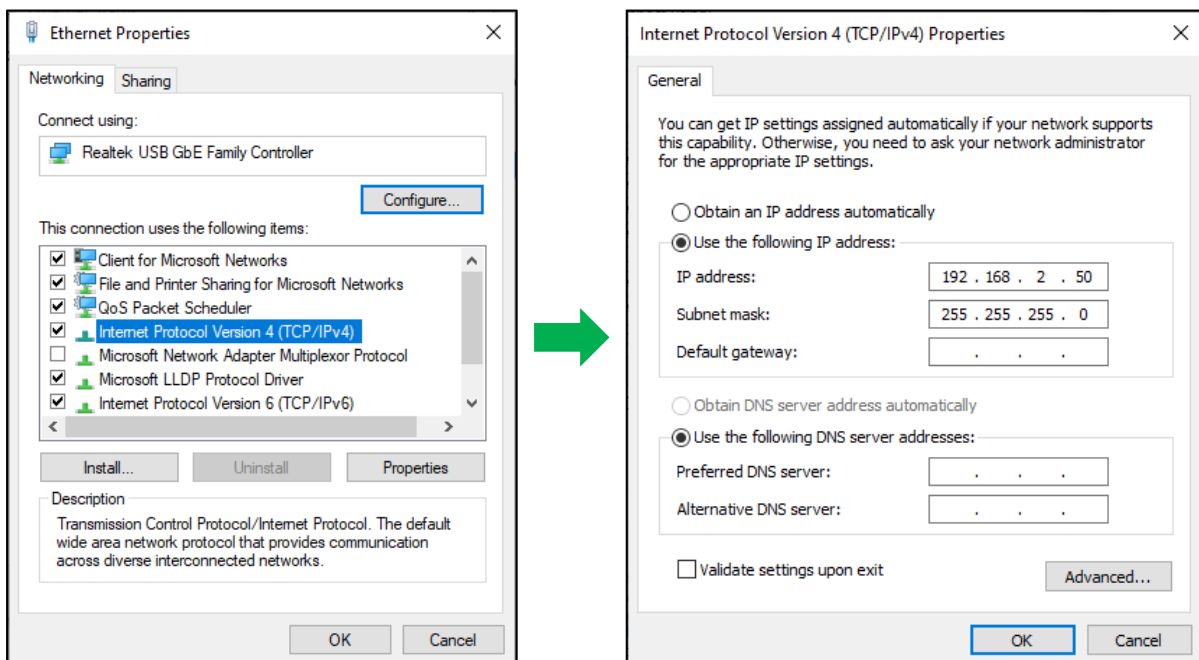

In the properties dialog which opens there will either be [Obtain an IP address automatically] or [Use the following IP address] selected. If an IP address is already present, make a note of it before changing any values since it will be needed if the computer is ever restored to the previous network.