

Gemini 720is

Real-time multibeam imaging sonar



With 120° field of view and a fast update rate of 30Hz, the Gemini 720is is ideal for poor visibility environments.

The Gemini 720is is supplied with Seanet Pro, Tritech's data acquisition and logging software, which offers users the ability to network and operate the sonar along with a range of other Tritech sensors from a single software interface.

The new Genesis software, which will in time replace Seanet Pro, is also supplied with the Gemini 720is. This Genesis software offers additional features such as target tracking and already allows you to run a number of other Tritech sensors alongside your Gemini 720is such as MicronNav USBL and Mechanical scanning sonars.

SeaTec software can also be used with the Gemini 720is. This advanced software package allows for automatic target identification, classification and tracking.

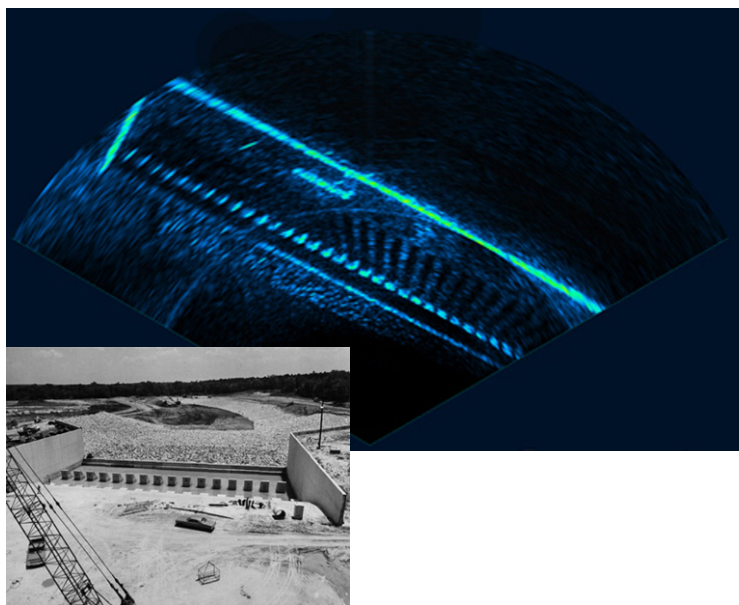

Low power underwater visualisation

The 720is is the latest generation from Tritech's renowned multibeam sonar range and offers a real-time, high frequency imaging solution.

The Gemini 720is operates at 720kHz and this combined with Tritech's state-of-the-art processing electronics, produces images of superb clarity.

Benefits

- Near field focusing
- 4mm range resolution
- Clear wide angle field of view
- Suitable for low visibility environments
- Easier interpretation of sonar imagery

Features

- 720kHz operating frequency
- CHIRP processing for high resolution imagery
- Wide 120° field of view
- Real-time updates for video like imagery
- Integrated velocimeter for accurate ranging
- Ethernet or VDSL communications
- Software development kit available

Applications

- ROV/AUV navigation
- Obstacle avoidance
- Target recognition
- Search and Rescue (SAR)
- Salvage operations
- Subsea monitoring and inspection
- Object detection

Specification

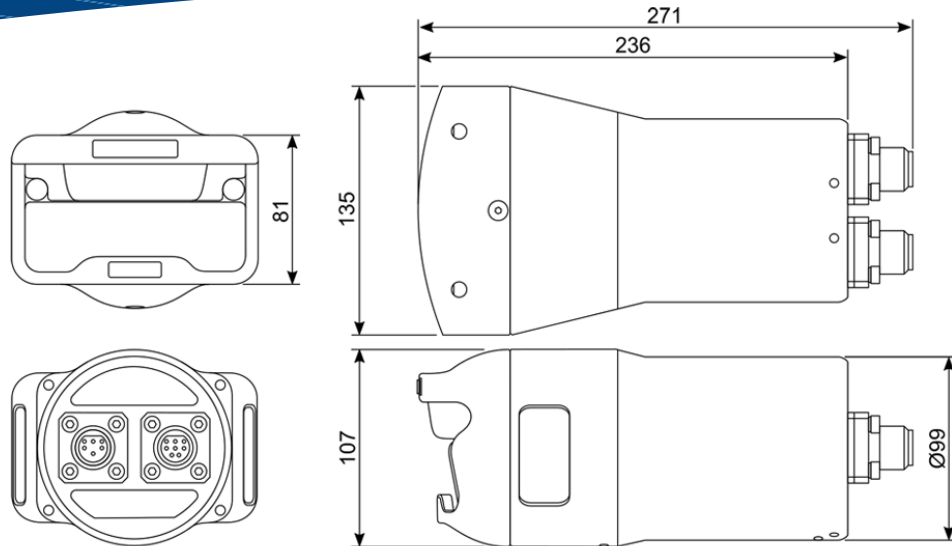

Not to scale, all dimensions in mm

Acoustic specifications	
Operating frequency	720kHz
Angular resolution	1.0° acoustic, 0.25° effective
Range	0.2m - 120m
Number of beams	512
Horizontal beamwidth	120°
Vertical beamwidth	20° (tilted down 10°)
Update rate	5 - 97Hz (range dependent)
Range resolution	4mm & 8mm ¹
CHIRP support	Yes
Speed of Sound	VoS sensor

Interface	
Supply voltage	19V to 74V DC
Power requirement	16W - 27W (range dependent) ²
Main port protocol	Ethernet or VDSL
Additional I/O	RS232, RS485 (half duplex), TTL in, Ethernet
Connector type	SeaCon 55 series, SubConn FCR 15 series or Schilling SeaNet (single port as standard)
VDSL cable length	Maximum length for VDSL and power is 300m, if power is provided locally the maximum length for VDSL communication is 500m

Physical specification	
Depth rating	1000m (aluminium), 4000m (titanium)
Weight in air	3.4kg (aluminium), 5.0kg (titanium)
Weight in water	1.3kg (aluminium), 3.0kg (titanium)
Temperature rating	-10°C to 35°C (operating), -20°C to 50°C (storage)

¹ Software switchable.

² The power consumption range quoted is accurate for a standalone unit and ignores cable losses.

Specification subject to change in line with Tritech's policy of continual product development

Marketed by:

Tritech International Limited
 Peregrine Road, Westhill Business Park
 Westhill, Aberdeenshire AB32 6JL
 United Kingdom
 email: tritech-sales@moog.com
 Tel: +44 (0)1224 744111

